



| Whirlpool Baths | Showers | Sanitaryware | Spas |

# JACUZZI® YOUNG COLLECTION PROJECT



WATER THAT MOVES YOU®



| Whirlpool Baths | Showers | Sanitaryware | Spas |



WATER THAT MOVES YOU®

**JACUZZI EUROPE S.P.A.**

**Socio Unico**  
A COMPANY OF JACUZZI BRANDS, INC. (USA)  
S.S. Pontebbana Km 97,200  
33098 VALVASONE (PN) Italia  
Tel. +39-0434-859111  
Fax +39-0434-85278  
<http://www.jacuzzi.eu>  
e-mail: [info@jacuzzi.it](mailto:info@jacuzzi.it)

**JACUZZI FRANCE s.a.s.**

ZA Le Vert Galant  
23 Avenue de l'éguilette  
BP 70673 SAINT OUEN L'AUMONE  
95004 Cergy Pontoise  
Tel. 0033(0)134401260  
Fax 0033(0)134400949  
<http://www.jacuzzi-france.com>  
e-mail: [info@jacuzzi-france.com](mailto:info@jacuzzi-france.com)

**JACUZZI ESPAÑA**

Jacuzzi Bathroom España, SL  
Passeig de Gràcia, 48 1º Bis 2º  
08007 BARCELONA  
Telf: 932385031 - 932384162  
Fax: 932385032 - 932722149  
<http://www.jacuzzi.eu>  
e-mail: [info-es@jacuzzi.it](mailto:info-es@jacuzzi.it)

**JACUZZI WHIRLPOOL GmbH**

Landsbergerstr. 110  
80339 MÜNCHEN - Deutschland  
Tel. (089) 50 05 98 6-0  
Fax (089) 50 05 98 6-50  
e-mail: [info-de@jacuzzi.it](mailto:info-de@jacuzzi.it)  
<http://www.jacuzzi.eu>

**JACUZZI MIDDLE EAST**

PO Box 500469  
Loft Office 3, Entrance B  
DUBAI MEDIA CITY  
Dubai, United Arab Emirates  
Tel. +971 (0) 4 3671416  
Fax +971 (0) 4 3672576  
e-mail: [info@jacuzzime.ae](mailto:info@jacuzzime.ae)



Il cuore che ama, è sempre giovane  
*A loving heart is forever young*



WATER THAT MOVES YOU®



## INDICE

### INDEX

6	Scopri il tuo stile personale <i>Discover your personal style</i>
10	VASCHE IDROMASSAGGIO <i>WHIRLPOOL BATHS</i>
16	Rivela
18	Versa
20	Invita
22	Uma
24	VASCHE DA BAGNO <i>BATHS</i>
26	BOX DOCCIA MULTIFUNZIONE <i>MULTIFUNCTIONS SHOWER CUBICLES</i>
32	Material 90
34	Material 100
36	Material Sphere
40	PARETINE DOCCIA <i>SHOWER PANELS</i>
42	Rei
44	IDROCOLONNE <i>HYDROCOLUMNS</i>
46	Nuda
48	Nuda Termae
50	Nuda Essential
52	CRISTALLI <i>GLASS PANELS</i>
56	Yncontra
60	Ynventa
62	RUBINETTERIA <i>BRASSWARE</i>
70	Dati tecnici <i>Technical data</i>

JACUZZI® YOUNG COLLECTION PROJECT



## TUFFATI IN UN NUOVO PROGETTO DI VITA

*DIVE INTO A PROJECT FOR A NEW LIFESTYLE*



Spogliati dalle convenzioni e dai luoghi comuni, tuffati in un mondo di sensazioni positive e di nuove tendenze. Young Collection Project è una novità nata dall'esperienza Jacuzzi®, dedicata a chi vuole vivere un nuovo concetto dell'idromassaggio e dell'ambiente bagno. Un'isola di relax o di divertimento, un habitat naturale o sofisticato, una fonte quotidiana di energia e di ispirazioni. Forme fresche e stimolanti, ispirate dalle ultime tendenze del design e della cultura dell'arredo. Tecnologie dell'ultima generazione, per offrirti tutte le performance dell'idromassaggio originale Jacuzzi®, con immediatezza e originalità. Semplicità e versatilità di ambientazione, per trasformare in realtà ogni idea, in armonia con tutti gli altri elementi, materiali e oggetti che compongono il bagno e la casa intera. Perché Young Collection Project non è solo una linea di vasche e box idromassaggio, è un modo di essere: il tuo.

*Get rid of conventions and clichés, jump into a world of positive sensations and new trends. Young Collection Project is newborn from the experience of Jacuzzi®, dedicated to those who want to experience a new hydromassage and bathroom concept. An island of relaxation and fun, a natural or sophisticated habitat, a daily source of energy and inspiration. Fresh and stimulating shapes, inspired by the latest design and furniture culture trends. The latest generation of technology to offer you all the performance of the original Jacuzzi® hydromassage, in a spontaneous and original way. Simplicity and versatility to transform each idea into something real, in harmony with all the other elements, materials and objects of which the bathroom and the entire home are made up of. Because the Young Collection Project is not just a line of whirlpool baths and hydromassage cubicles, it is a way of life: yours.*



**SCOPRI IL TUO STILE PERSONALE**  
*DISCOVER YOUR PERSONAL STYLE*



Young Collection Project nasce da uno studio approfondito degli stili di vita contemporanei, nonché dei nuovi significati che oggi assume l'ambiente bagno. Uno spazio protagonista della casa, da progettare e interpretare in modi sempre diversi, spesso sorprendenti. Una molteplicità di stili che la ricerca Jacuzzi® ha raggruppato in tre mondi distinti: **POP, ENERGY, LIVE**. Scopri quale di essi riflette meglio la tua personalità... ti aiuterà a scegliere il tuo modello ideale!

*The Young Collection Project is born from in-depth study of contemporary lifestyles, as well as from the new meanings that the bathroom has taken on today. A space that is the star of the home, to plan and interpret in ways that are always different, often surprising. A multitude of styles that the Jacuzzi® research has grouped together in three distinct worlds: **POP, ENERGY, LIVE**. Discover which of these better reflects your personality... it will help you choose your ideal model!*

**POP**



**ENERGY**



**LIVE**



**LIBERTÀ PURA E SEMPLICE**  
*PURE AND SIMPLE FREEDOM*

**POP**

"Mi piace stare in mezzo alla gente e divertirmi senza pensieri...  
Sono questi i momenti della vita che  
mi regalano più emozioni e credetemi, momenti così speciali li  
ritrovo nel mio bagno..."

*Giulia, 34 anni. Account Director di una agenzia di comunicazione*

Sei un tipo estroverso e ami sognare ad occhi aperti? Ti impegni con tutte le tue energie nella vita e nel lavoro, ma ti piace anche immergerti nel relax? Ti informi sulle ultime mode... e poi scegli di testa tua? Se la risposta è "sì", allora sei un tipo POP e la tua personalità emerge in tutto quello che ti circonda e che fa parte del tuo mondo privato: la tua casa, il tuo ambiente bagno e naturalmente, il tuo modello Young Collection Project. Un design che si distingue subito e nel quale ti riconosci completamente, un flusso di sensazioni benefiche e vitali, una semplicità che diventa stile ed una totale libertà di installazione e abbinamento, per creare il tuo spazio personale.

*"I like to be with people and have carefree fun... These are the moments in life that give me more emotions and, believe me, I experience such special moments in my bathroom."*

*Giulia, 34 years old. Account Director of a communication agency*

*Are you an extrovert who likes to day dream? Do you get totally involved in your life and in your job, but also like to fully relax? Are you well-informed on the latest fashions...and then choose according to your taste? If the answer is "yes". then you are the POP type and your personality emerges in everything that surrounds you and that is part of your private world: your home, your bathroom, and your Young Collection Project model, of course. A design that distinguishes itself straight away and in which you can recognise yourself completely, a flow of beneficial and vital sensations, a simplicity that becomes style and total freedom of installation and combination, to create your personal space.*





# ENERGY

## AVVENTURA QUOTIDIANA DAILY ADVENTURE

“È come avere la spiaggia in casa. Ci si può rilassare divertendosi. Quando entro nel mio bagno, mi sembra quasi di essere in vacanza...”

*Guido, 28 anni, architetto*

Immagina di essere al mare e mentre tutti si godono pigramente il sole, tu stai cavalcando le onde sul tuo kite surf... hai già vissuto questo momento? Bene, il tuo mondo è ENERGY: un modo di essere fatto di vitalità e divertimento, passione per la tecnologia e per le performance, attenzione alle cose concrete ed essenziali, ma anche piacere di goderti il meglio della vita e di condividerlo con chi ami. Oggi puoi ritrovare tutto questo in Young Collection Project: linee minimali, soluzioni all'avanguardia, prestazioni straordinarie per tonificarti ed energizzarti... prima di partire verso nuove avventure.

*“It's like having a beach at home. You can relax while having fun. When I get into my bathroom, I almost feel as if I am on holiday...”*

*Guido, 28 years of age, architect*

*Imagine you are on the beach and, while everyone else is lying lazily in the sun, you are riding the waves on your kite surf....have you ever experienced this? In that case, your world is ENERGY: a lifestyle of vitality and fun, passion for technology and for performances, attention to concrete and essential things, but also the pleasure of enjoying the best of life and sharing it with those you love. Today, you can find all this in Young Collection Project: minimalist lines, avant-garde solutions, extraordinary performances to tone and energize you...before setting off for a new adventure.*

**QUALITÀ DELLA VITA**  
*THE QUALITY OF LIFE*

**LIVE**

“La mia nuova vasca Jacuzzi® Young Collection Project piace a tutta la famiglia, mio marito trova sempre la scusa per usarla e i miei figli ci passano le ore...”  
*Alessia, 40 anni, avvocato civile*

La tua casa è il tuo mondo, ed il bagno è il suo luogo più intimo e tranquillo. Uno spazio che rispecchia la tua interiorità ed i valori in cui credi: sicurezza, qualità, durata. Tutto questo però non ti basta, vuoi ancora di più: il prestigio di una firma unica al mondo, il fascino di un design originale, la scelta fra più funzioni diverse, con un semplice gesto. LIVE è il tuo stile, Young Collection Project il tuo modo di scoprire tutte le sensazioni e le emozioni che può darti il tuo ambiente bagno, insieme a chi ami. Una scelta che ti rigenera, ti tranquillizza, ti avvolge... in poche parole, ti migliora la casa e la vita.

*“My whole family likes my new Jacuzzi® Young Collection Project bath, my husband always has an excuse to use it, and my kids soak in it for hours...”*  
*Alessia, 40 years of age, civil lawyer*

*Your home is your world, and the bathroom is its most intimate and serene place. A space that reflects your inner self and the values you believe in: safety, quality, duration. All this is not enough though, you want even more: the prestige of a brand that is unique in the world, the charm of an original design, the choice of various functions, with a simple gesture. LIVE is your style, Young Collection Project your way of discovering all the sensations and emotions that your bathroom can give you, together with the one you love. A choice that regenerates you, calms you, envelops you... in just a few words, improves your home and your life.*



**VASCHE IDROMASSAGGIO**  
*WHIRLPOOL BATHS*







### **TRE MODI DI PROVARE UNA SENSAZIONE UNICA**

Nessun idromassaggio ti può dare le stesse sensazioni dell'idromassaggio Jacuzzi®: profondo, vitalizzante, calibrato. Ma non è tutto: con Young Collection Project sei tu a scegliere le varie combinazioni fra i diversi getti, a seconda dei tuoi desideri.

### **THREE WAYS OF EXPERIENCING A UNIQUE SENSATION**

*No hydromassage can give you the same sensations as the Jacuzzi® hydromassage: deep, revitalising, balanced. But that's not all: with Young Collection Project you are the one who chooses the various combinations from the different jets, depending on your wishes.*





## JET

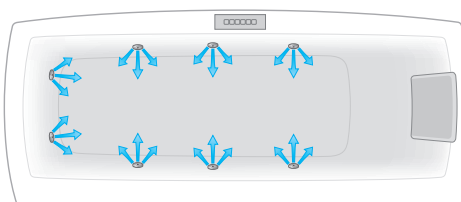

## AIR

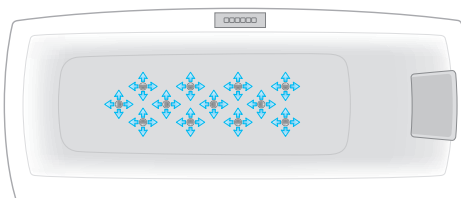

## DUO

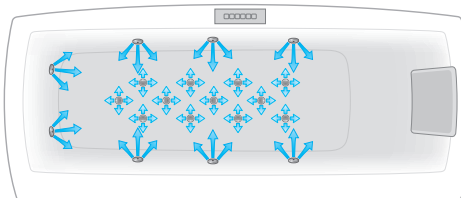

**JET** è la più recente evoluzione dell'idromassaggio originale Jacuzzi®: un autentico mito nel mondo del bagno. La sua perfetta miscela di acqua e aria, scientificamente diretta verso le zone del corpo, **stimola la circolazione, rilassa i muscoli e tonifica i tessuti**, con la giusta potenza. È disponibile in due configurazioni intercambiabili: **HYDRO JET** con bocchette fisse e direzionabili, per un trattamento energetico e localizzato, **TWIST JET** con un getto rotante meno intenso ma più esteso in ampiezza.

*JET is the most recent evolution of the original Jacuzzi® hydromassage: an authentic myth in the bathroom world. Its perfect mixture of water and air, scientifically directed at the right power towards specific areas of the body, **stimulates circulation, relaxes muscles and tones tissue**. It is available in two interchangeable configurations: **HYDRO JET** with fixed and adjustable jets, for an energetic and localised treatment, **TWIST JET** with a less intense but more extended rotating jet.*

**AIR** è l'anima divertente dell'idromassaggio Jacuzzi®, una sorgente di bollicine che accarezzano tutto il corpo, regalandogli nuova **vitalità ed energia**. Decidi tu la loro intensità: le preferisci frizzanti e vigorose, oppure morbide e vellutate? La disposizione delle bocchette è stata accuratamente studiata per armonizzarsi al design ricercato delle vasche Young Collection Project.

*AIR is the fun soul of the Jacuzzi® hydromassage, a source of bubbles that massage your whole body, giving you new **vitality and energy**. You decide their intensity: do you prefer them to be bubbly and vigorous or soft and smooth? The arrangement of the jets has been accurately studied to harmonise with the refined design of the Young Collection Project baths.*

**DUO** è la formula più completa dell'idromassaggio Young Collection Project, un mix perfetto di JET e AIR per vivere un'esperienza totale, comodamente nel tuo bagno. Tutta la sapienza e la fluida intensità dell'idromassaggio originale Jacuzzi®, tutto il divertimento e l'energia di infinite bolle d'aria che stimolano e rilassano allo stesso tempo. Una scelta ideale per chi vuole godersi il massimo della vita, in ogni istante.

*DUO is the most complete formula of the Young Collection Project hydromassage, a perfect mixture of JET and AIR for a total whirlpool experience while soaking comfortably in your bathtub. All the wisdom and the fluid intensity of the original Jacuzzi® hydromassage, all the fun and energy of the endless air bubbles that simultaneously stimulate and relax. An ideal choice for those who want to enjoy the best of life, at all times.*



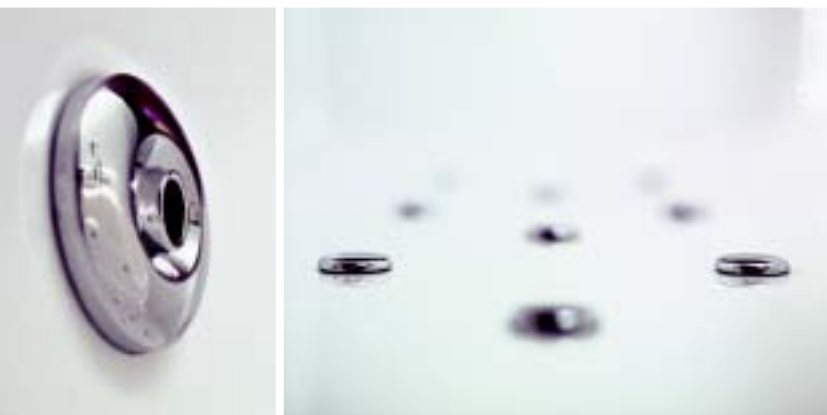

## UNO STILE SPECIALE NELL'IDROMASSAGGIO

Le bocchette idromassaggio delle vasche Young Collection Project: oltre 50 anni di esperienza Jacuzzi® in una forma fresca, vitale e speciale. Il segreto della perfetta miscela di aria e acqua sprigionata da queste bocchette, è il sistema Venturi: Jacuzzi® è stata la prima a introdurre questa tecnologia in una vasca da bagno domestica, ed è da sempre all'avanguardia nel suo sviluppo, per garantire una potenza ideale e una reale efficacia dell'idromassaggio sull'organismo. Le bocchette Young Collection Project si possono infatti **orientare di 20°** per ottenere un **trattamento mirato e personalizzato**: ad esempio dirigendo i getti sulle fasce muscolari più tese o sui punti "chiave" del sistema linfatico. Inoltre il loro design, liscio e arrotondato, è in perfetta armonia con il comfort ergonomico e l'armoniosa estetica della vasca.

## A SPECIAL STYLE OF HYDROMASSAGE

*The hydromassage jets of the Young Collection Project baths: over 50 years of Jacuzzi® experience in a fresh, vital and special form. The secret of the perfect mixture of air and water released by these jets is the Venturi system: Jacuzzi® was the first to add this technology to a household bathtub and has always been in the foreground in its development to ensure ideal power and real hydromassage efficiency for the body. The Young Collection Project jets can in fact be **directed at 20°** to obtain a **focused and personalised treatment**, for example by directing the jets to the most tensed up muscles or on the most important spots of the lymphatic system. Furthermore, its smooth and rounded design is in perfect harmony with the ergonomic comfort and the harmonious aesthetics of the bathtub.*

## LUMINA, BRILLANTE INNOVAZIONE

Un'idea luminosa, che rende ancora più bella la vasca e l'intero ambiente bagno: è Lumina, il **pannello comandi** che con un semplice tocco, diventa una fonte di colore e illuminazione, oltre che di funzionalità. Basta sfiorarlo e come per magia, Lumina si accende e si mette a tua disposizione, permettendoti di controllare e impostare l'idromassaggio a piacimento, muovendo solo un dito. Il massimo della semplicità e della precisione, con uno stile emozionante e speciale. Puoi attivare o disattivare le 8 bocchette JET e regolarne la potenza, per goderti un idromassaggio energetico o delicato. Oppure inserire e disinserire il sistema AIR che sprigiona miriadi di bollicine, con un effetto più o meno intenso. Inoltre puoi attivare l'impianto di disinfezione per igienizzare il circuito idraulico della vasca, garantendo un'igiene totale e duratura: sempre con la massima facilità.

## LUMINA, BRILLIANT INNOVATION

A luminous idea, that makes the bathtub and the whole bathroom even more beautiful: this is Lumina, the **control panel** that becomes a source of colour and illumination, as well as of functionality, with a simple touch. Simply touch it lightly and, like magic, Lumina lights up and is ready for you, allowing you to control and set the hydromassage as you wish, with the touch of a finger. The best in simplicity and precision, with an exciting and special style. You can start or stop the 8 JETS and adjust their power to enjoy an energetic or delicate hydromassage. Or you can switch the AIR system on or off to release myriads of bubbles with an effect of greater or lesser intensity. In addition to this, you can activate the disinfecting system to disinfect the hydraulic system of the bathtub, guaranteeing total hygiene and duration, at all times and with utmost ease.



### + AIR

Aumenta l'effetto frizzante ed energizzante delle bollicine d'aria.

*Increases the sparkling and energy-boosting effect of the air bubbles.*



### - AIR

Diminuisce la quantità di bollicine, per un effetto più carezzevole.

*Decreases the quantity of air bubbles, for a more gentle massage.*



### on/off AIR

Attiva e disattiva il sistema AIR durante il bagno.

*Turns the AIR system on and off during the bath.*



### DISI

Attiva l'impianto di disinfezione, per igienizzare la vasca e l'impianto idromassaggio.

*Turns the disinfection system on, to disinfect the bathtub and the hydromassage system.*



### +/- JET

Regola l'intensità dei getti per un massaggio energetico o rilassante.

*Adjusts the intensity of the jets for an energetic or relaxing massage.*



### on/off JET

Attiva e disattiva le bocchette idromassaggio JET.

*Turns the hydromassage jets on and off.*

## RIVELA

designer: IED Centro Ricerche

Scopri il divertimento e il benessere dell'idromassaggio originale Jacuzzi®, esplora molteplici possibilità di inserimento e abbinamento. Rivela è la prima espressione di un nuovo progetto di arredo e di vita in bagno: design lineare e armonioso, tecnologie evolute e comodo cuscino poggiatesta. Disponibile con idromassaggio Jet, Air, Duo e in versione destra o sinistra, per sfruttare ogni spazio nel modo migliore.

*Discover the fun and well-being of the original Jacuzzi® hydromassage, explore the many installation possibilities and combinations. Rivela is the first expression of new furnishing project for a new bathroom lifestyle: a linear and harmonious design, evolved technologies and a comfortable headrest cushion. Available with the Jet, Air, Duo hydro-massage and in the right or left version, to make the most of any space in the best possible way.*





170x70 · 170x75



## VERSA

designer: IED Centro Ricerche

Versa è la versatilità che prende forma, nelle funzioni come nell'ambientazione. Il lato piedi diritto permette una facile installazione dovunque, anche a nicchia. La scelta fra più versioni offre a ciascuno una soluzione ideale: con idromassaggio Jet, Air, Duo oppure semplice vasca da bagno. Il pannello comandi Lumina aggiunge un tocco "high tech": basta sfiorarlo per accenderlo e controllare tutte le funzioni. Disponibile anche con impianto di sanitizzazione optional.

*Versa is versatility that takes shape, in terms of functions and of setting. The straight foot end makes it easy to install, even in an alcove. The choice of various versions offers everyone their ideal solution: with the Jet, Air or Duo hydromassage or in the simple bathtub version. The Lumina control panel adds a "hi-tech" touch: simply brush against it to switch it on and control all the functions. Also available with an optional sanitising system.*





170x78



180x78





## INVITA

designer: IED Centro Ricerche



Ti invitiamo a scoprire la nuova dimensione del piacere, della bellezza e dell'energia. Linee fluide ed ergonomiche, in sintonia con il tuo stile. Doppio poggiatesta e fondo simmetrico, per farti godere l'idromassaggio Jacuzzi® a scelta sulla schiena o sui piedi, in versione Jet, Air o Duo. Totale versatilità di installazione, anche a centro parete, per trasformare il tuo bagno in uno spazio di benessere e fitness... è proprio impossibile resistere a Invita.

*We invite you to discover the new dimension of pleasure, of beauty, of energy. Flowing, ergonomic lines, in harmony with your style. Two headrests and a symmetric base so that you can enjoy the Jacuzzi® hydromassage on your back or on your feet, in the Jet, Air or Duo version. Full installation versatility, even at the centre of the wall, to transform your bathroom into a wellness and fitness area...it's really impossible to resist to Invita.*





130x130





## UMA

designer: IED Centro Ricerche



Uma è la classe di un design ampio e avvolgente, la scelta fra molteplici funzioni e possibilità di fruizione, il benessere di una totale immersione nell'idromassaggio Jacuzzi® in versione Jet, Air oppure Duo. Il morbido cuscino poggiatesta e la seduta ergonomica sull'angolo, utilizzabile anche come portaoggetti, aggiungono un visibile prestigio e un sensibile comfort. Un angolo di paradiso, per chi vuole il massimo nel proprio ambiente bagno.

*Uma is the class of an ample and enveloping design, the choice of many functions and possibilities of use, the well-being of full immersion in the Jacuzzi® hydromassage in the Jet, Air or Duo versions. The soft headrest cushion and the ergonomic seat in the corner that can also be used as a toiletry shelf, add visible prestige and definitive comfort. A corner of paradise, for those who want the most from their bathroom.*



## VASCHE DA BAGNO

BATHS



La ricerca Jacuzzi® sui nuovi stili di vita, il benessere di una perfetta ergonomia e la qualità dei migliori materiali, in una gamma di vasche senza idromassaggio per arredare, interpretare, vivere il tuo spazio bagno. Scegli liberamente il tuo modello ideale, in forme diverse e dimensioni dinamiche. Prova la comodità del poggiatesta e immergi completamente il tuo corpo nel caldo abbraccio dell'acqua, grazie al design avvolgente del guscio. Le vasche Young Collection Project, con o senza idromassaggio, possono essere completate con la parete in cristallo sfumato Yncontra, per creare uno spazio doccia completamente originale ed esclusivo.

*The research of Jacuzzi® on new lifestyles, the well-being of perfect ergonomics and the quality of the best materials, in a range of non jetted baths to furnish, interpret, live in your bathroom space. Choose your ideal model in complete freedom, from various shapes and dynamic dimensions. Try out the comfort of the headrest cushion and completely soak your body in the warm embrace of water thanks to the enveloping design of the shell. The Young Collection Project baths, with or without hydromassage, can be completed by the Yncontra glass shower panels to create a completely original and exclusive shower space.*

## RIVELA

170x70  
170x75





**VERSA**  
170x78



**INVITA**  
180x78



**UMA**  
130x130

**BOX DOCCIA MULTIFUNZIONI**  
*MULTIFUNCTION SHOWER CUBICLES*







## INNOVAZIONE IN TUTTI I SENSI

Nei box doccia Young Collection Project, l'innovazione si vede, si tocca, si vive in ogni istante e particolare: in un grande ambiente come in uno spazio di dimensioni ridotte, sempre con il fascino di un **design all'avanguardia**, il piacere di **performance avanzate** e il vantaggio della massima **versatilità di installazione**. Guarda la loro estetica minimalista, con doccia a cascata e soffione a pioggia direttamente integrati nelle strutture di sostegno: una sintesi totale di forma e funzione. Sfiora le morbide forme della colonna priva di spigoli, in tre varianti di colore: rosso acero con tonalità cangiante a seconda del punto di vista dell'osservatore, alluminio micropallinato che dà una particolare sensazione tattile e visiva, bianco totale per armonizzarsi con qualsiasi contesto cromatico.

## INNOVATION IN ALL SENSES

*In the Young Collection Project shower cubicles innovation can be seen, touched, experienced at any time and in every detail: in a large room and likewise in a small space, always with the charm of **avant-garde design**, the pleasure of **advanced performances** and the advantage of utmost **versatility of installation**. Look at their minimalist design, with their waterfall shower feature and raindrop fixed shower head integrated in the supporting structure. A total synthesis of shapes and functions. Touch the smooth curvy shapes of the column, available in three colour options: maple red with tones that change depending on the point of view of the observer, micro-shot peened aluminium that gives it a special feel and appearance or total white to harmonise with any colour context.*





Il design dei box doccia Young Collection Project soddisfa con creatività tutte le tue necessità pratiche, e in più ti offre delle inedite sensazioni tattili e visive. Il **piatto** è realizzato in **Techstone** bianco, un nuovo materiale sorprendentemente caldo e vellutato. La **seduta** ergonomica si apre e si chiude senza ingombrare l'interno, **con un movimento "soft"**: nei box doccia Young Collection Project, l'energia è sempre associata alla dolcezza. Il comfort e la libertà di movimento sono totali, grazie alla scelta fra diverse dimensioni, anche con innovativa pianta ad arco di cerchio per ottimizzare lo spazio disponibile. E con i cristalli a muro e la pedana in Techstone, anch'essi bianchi, puoi integrare il box nell'architettura del bagno, sempre nel segno di un'estetica rigorosa ed essenziale. Il doppio trattamento **Crystal Clear®** protegge entrambe le superfici dei cristalli e le mantiene brillanti e trasparenti, grazie alla sua formula esclusiva che combatte il calcare e rende più facile la pulizia.

*The design of the Young Collection Project shower cubicles creatively satisfies all practical necessities and, in addition to this, offers you original tactile and visual sensations. The **tray** is made of white **Techstone**, a surprisingly warm and silky-smooth new material. The ergonomic **seat** is folded in and out without taking up unnecessary space and **with a soft movement**: in the Young Collection Project shower cubicles, energy is always associated with gentleness. Comfort and freedom of movement are total, thanks to the choice of various sizes, even the innovate arched shape to make the most of the space available. Thanks to the glass wall panels and the Techstone duckboard, both white, the cubicle fits easily into the bathroom architecture while preserving rigorous and minimalist aesthetics. The double **Crystal Clear®** treatment protects both sides of the glass panels, keeping them shiny and clear, thanks to its exclusive formula that fights limescale and makes cleaning easier.*







Oltre che nei materiali e nel design, i box doccia Material sono all'avanguardia anche nelle tecnologie, per farti vivere il bagno in maniera completamente nuova.

**Doccia a cascata**, per liberarsi dallo stress e ricaricarsi di energie positive.

**Soffione a pioggia** con getto di forma triangolare, che irrorava una superficie più ampia rispetto ai soffioni tradizionali.

**Miscelatore** dal design studiato per armonizzarsi con la colonna centrale senza spigoli, in due versioni: **manuale oppure termostatico**, per avere sempre l'acqua alla temperatura preferita.

**Pratico doccino con flessibile**, sempre a portata di mano per ogni esigenza.

**Idromassaggio Jet verticale**, per tonificare e rilassare la muscolatura della schiena.

*As well as in terms of materials and design, the Material shower cubicles are well ahead of time for as much as regards technologies, so that you can live your bathroom experience in a completely new way.*

**Waterfall shower feature**, to relieve stress and recharge with positive energies.

**Fixed raindrop showerhead** with a triangular-shaped jet that covers a larger surface than traditional showerheads.

**A mixer** with a design studied to harmonise with the smooth-edged central column, available in two versions: **manual or thermostatic**, for water that always has a perfect temperature.

**Practical hand shower with hose**, always ready for use.

**Vertical hydromassage Jet**, to tone and relax the back muscles.



**Bagno turco** con doppio dispenser, per determinare una temperatura perfetta e per aromatizzare il vapore con la propria essenza preferita.

Lo stesso design del box, favorisce una perfetta fruizione di questa pratica purificante e rigenerante: generatore di vapore a incasso per liberare al massimo lo spazio interno, colonna dalle forme studiate per distribuire il vapore all'interno, senza sbalzi di temperatura, tetto con uscita per il vapore.

*Steam bath with a double dispenser for a perfect temperature and to perfume the steam with your favourite essence.*

*The actual design of the cubicle favours perfect use of this purifying and regenerating practice. The steam generator is recessed to leave more space inside the cubicle, the shape of the column has been designed to distribute the steam inside without changes of temperature. The roof has a steam outlet.*



## MATERIAL 90

designer: IED Centro Ricerche

Nato dalla collaborazione con i ricercatori dell'Istituto Europeo di Design IED, in simbiosi con l'innovazione tecnologica Jacuzzi®, Material introduce nuovi concetti di ambientabilità, semplicità e rigenerazione nell'ambiente bagno. Una filosofia rispecchiata in ogni particolare: dai sostegni con soffione doccia e cascata d'acqua integrati, all'essenzialità formale e preziosità tattile del piatto in Techstone. E dal design dei gruppi di miscelazione in due versioni, termostatico o manuale, alla colonna completamente senza spigoli, in tre colori di moda: rosso acero, bianco e alluminio micropallinato, per rappresentare uno stile di vita e d'arredo.

*Born from the collaboration with the researchers of the Istituto Europeo di Design IED (European Design Institute) together with the technological innovation of Jacuzzi®, Material introduces new adaptability, simplicity and regeneration concepts into the bathroom. A philosophy that is reflected in every detail: from the rails with their integrated fixed shower head and waterfall function, to the formal minimalism and the tactile preciousness of the Techstone tray. And again, from the design of the mixers in two versions, thermostatic or manual, to the wonderfully smooth-edged column available in three fashionable shades: maple red, white and micro-shot peened aluminium, to represent a life and furnishing style.*





70x90x226



75x100x226





## MATERIAL 100

designer: IED Centro Ricerche



L'innovazione estetica e tecnologica di Material mantiene la proporzione fra dimensioni contenute e ampia abitabilità interna anche nel 75x100. Con soffione a pioggia e doccia a cascata integrati nei supporti della parete trasparente con porta scorrevole, bagno turco con generatore a incasso, seduta reclinabile con apertura "soft", piatto in Techstone e colonna con bordi arrotondati, dotata di gruppo di miscelazione termostatico o manuale. Una soluzione che unisce raffinato prestigio e piacere delle performance più pure e avanzate, offrendo la scelta fra tre diverse colorazioni della colonna: rosso acero, bianco e alluminio micropallinato.

*The aesthetic and technological innovation of Material preserves the proportion between a limited size and good interior liveability also in the 75x100 version. Supplied with the fixed raindrop shower head and the waterfall feature integrated in the supports of the transparent panel with sliding door, steam bath with recessed generator, adjustable, soft-opening seat, Techstone tray and soft-edged column, fitted with a thermostatic or manual mixer. A solution that combines refined prestige with the pleasure of the purest and most advanced performances, offering a choice of three different column colours: maple red, white and micro-shot peened aluminium.*



## MATERIAL SPHERE

designer: IED Centro Ricerche

Il progetto Material estende le sue valenze innovative anche in spazi ristretti o problematici, con Material Sphere. La sua forma ad arco di cerchio rende più fruibile lo spazio centrale, distanziandolo maggiormente dall'angolo rispetto ai box tradizionali. L'attacco a parete da 70 cm consente di installare un box di dimensioni 90x90 cm anche in prossimità di una porta o in altri spazi dove non sarebbe altrimenti possibile. Tutto questo, con il prestigio innovativo di tutti i modelli Material: soffione a pioggia e doccia a cascata integrati nella struttura, bagno turco, seduta reclinabile, piatto in Techstone, colonna nei colori rosso acero, bianco e alluminio micropallinato: una scelta in armonia con il tuo stile.

*The Material project even extends its innovative qualities to restricted or problem spaces, thanks to Material Sphere. Its arched shape makes the central space easier to use, creating a larger gap between it and the corner compared to traditional cubicles. The 70 cm wall connection makes it possible to install a 90x90 cm cubicle even near a door or in other spaces where it would otherwise be impossible. All this comes with the innovative prestige of all the Material models: fixed raindrop shower head and waterfall feature integrated in the structure, steam bath, adjustable seat, Techstone tray, column available in red maple, white and micro-shot peened aluminium: a choice in harmony with your style.*





70x70x226





**IL TUO BAGNO YOUNG**  
*YOUR YOUNG BATH*





## PARETINE DOCCIA

SHOWER PANELS



### UNA NUOVA EMOZIONE IN BAGNO

Un nuovo concetto si fa spazio in bagno: non una semplice **paretina doccia**, ma un elemento energizzante e caratterizzante, vivace nei colori e facile da inserire in qualsiasi contesto. Esteticamente in sintonia con le nuove tendenze dello spazio giorno, per esprimere una visione trasversale dell'arredo domestico, Rei è realizzata in Coeso: un nuovo materiale antimacchia, antiruggine e antibatterico, ideale per lo spazio doccia. Può essere installata a muro, ad angolo oppure sopra la vasca, per creare un pratico e innovativo combinato.

### A NEW EMOTION IN THE BATHROOM

A new concept makes its way into the bathroom: not just a **shower panel** but an energy-boosting and distinguishing element, brightly coloured and easy to fit into any context. Aesthetically in harmony with the new living room trends to express a transversal view of home furniture, Rei is made from Coeso: a new stainproof, rustproof and antibacterial material that is ideal for the shower. It can be installed back-to-wall, in a corner or over the bathtub to create a practical and innovative combination.



## REI

designer: IED Centro Ricerche

Rei riunisce il meglio della tecnologia Jacuzzi® e offre una scelta completa di funzioni: soffione a pioggia per una doccia rigenerante, doccetta a mano con flessibile, idromassaggio verticale con quattro getti, per tonificare i muscoli della schiena, miscelatore in versione manuale oppure termostatica, per godersi subito l'acqua alla propria temperatura ideale. Tre i colori disponibili: giallo pop per chi vuole esprimere uno stile estroverso e anticonvenzionale, bianco per chi ricerca la massima purezza, glicine metalizzato iridescente per chi è affascinato dalle nuove tecnologie.

*Rei put together the best of Jacuzzi® technology and offers a complete choice of functions: fixed raindrop showerhead for a regenerating shower, a hand shower with hose, a vertical hydromassage with four jets to tone back muscles, a manual or thermostatic mixer, to enjoy water at an ideal temperature, straight away. Three colours are available: pop yellow for those who want to express an extrovert and unconventional style, white for those who look for maximum purity, metallic wisteria, iridescent for those fascinated by new technologies.*





17x143 | angolare o a parete - *corner or back to wall*



## IDROCOLONNE HYDROCOLUMNNS



### LA PURA BELLEZZA DELL'ACQUA

Oggetto di design o rubinetteria? Due anime in un unico corpo cromato: è Nuda, una scelta di assoluta **essenzialità e funzionalità**, con in più un'estetica originale e creativa. Un elemento innovativo, in tre diversi modelli: per godersi una doccia rigenerante, ma anche per divertirsi a "giocare" con l'acqua, grazie ai getti verticali. La selezione della temperatura è sempre perfetta, con il **miscelatore manuale o termostatico**. Nelle versioni con attacco a parete di interasse 150mm l'installazione è particolarmente facile anche nelle ristrutturazioni o in sostituzione di una rubinetteria tradizionale.

### THE PURE BEAUTY OF WATER

*Is it a design feature or a tap? Two souls in a single chrome body: this is Nuda, an **absolutely minimalist** and functional choice with an original and creative appearance. An innovative element, available in three different models: to enjoy a regenerating shower but also to have fun and play with the water, thanks to the vertical jets. The temperature selection is always perfect, thanks to the **manual or thermostatic mixer**. In the version where the pipe connections are on the wall with a distance between them of 150 mm, installation is particularly easy even when renovating an old shower or replacing traditional tapware.*





## NUDA

Un'idea brillante e inimitabile, per godersi tutta la rigenerazione e il divertimento dell'elemento acqua. Dotata di doccia, doccetta con flessibile, 4 getti idromassaggio verticali e deviatore, va abbinata con un miscelatore monocomando o termostatico ad incasso.

*A brilliant and inimitable idea, to enjoy all the regenerating qualities and fun of water. Fitted with a shower, a hand shower with hose, 4 vertical hydromassage jets and a diverter switch, it goes with a single-lever or thermostatic built-in mixer.*





11x155 | a parete - *back to wall*



30x150 | a parete - *back to wall*





## NUDA THERMAE



Perfetta armonia di forma e funzione, in questa versione con doccia, doccetta con flessibile, 2 getti idromassaggio verticale, miscelatore termostatico e attacco a parete di interasse 150mm.

*Perfect harmony of shape and functions in this version with shower, hand shower with hose, 2 vertical hydromassage jets, thermostatic mixer and 150 mm centre-to-centre distance pipe connection on the wall.*

## NUDA ESSENTIAL

L'essenza del minimalismo, per chi vuole rivoluzionare l'ambiente bagno con la massima immediatezza. Dotata di doccia, doccetta flessibile, miscelatore termostatico e attacco a parete di interasse 150mm.

*The essence of minimalism for those who want to revolutionise the bathroom in the wink of an eye. Supplied with a shower, a shower head with hose, a thermostatic mixer and a 150 mm centre-to-centre distance pipe connection on the wall.*





30x150 | a parete - *back to wall*



**CRISTALLI**  
*GLASS PANELS*





## ARCHITETTURE DI CRISTALLO

Dimentica lo spazio doccia come lo hai sempre vissuto ed entra in una dimensione di **trasparenza e libertà**. Scopri anche tu il fascino e la libertà di Yncontra e Ynventa: due nuovi sistemi per completare e rendere ancora più unico il tuo ambiente bagno. Yncontra e Ynventa rinnovano la stessa estetica del cristallo, grazie alla finitura sfumata che unisce privacy e trasparenza, come in una dissolvenza che avvolge il corpo. A questo si aggiunge il trattamento esclusivo **Crystal Clear®** (su ambo i lati) che facilita la pulizia e protegge la superficie dall'azione corrosiva del calcare e dei detersivi.

## GLASS ARCHITECTURES

*Forget the shower space as you have always experienced it and welcome to a dimension of **transparency and freedom**. Discover the charm and freedom of Yncontra and Ynventa: two new systems to complete your bathroom and make it even more unique. Yncontra and Ynventa renew the appearance of glass thanks to the hazy finish that combines privacy and transparency, like in a mist that envelops the body. Now add the exclusive **Crystal Clear®** treatment (on both sides) that makes cleaning easier and protects the surface from the corrosive action of limescale and of detergents.*





**CRISTALLI**  
*GLASS PANELS*





 CRYSTAL CLEAR  
by JACUZZI®

## YNVENTA

Ynventa è il programma di pareti in cristallo che permette di creare le più diverse configurazioni di cabina doccia, a partire da quattro semplici elementi modulari e componibili. Inoltre si possono combinare cristalli curvi e lineari a piacimento, per dare forma a soluzioni inedite e personalizzate. L'installazione a filo pavimento sottolinea un'estetica assolutamente essenziale, mentre il porta oggetti in cristallo e l'appendino esterno per l'accappatoio, rivelano uno studio attento del rapporto tra forma e funzione.

*Ynventa is the glass panel programme that allows you to create the most varied shower cubicle configurations starting with just four simple modular elements. Furthermore, you can combine curved and straight glass panels at will to create unusual and personalised solutions. Installation flush with the floor sets off absolutely minimalist looks while the glass shelf and the exterior bathrobe hook reveal a careful study on the link between shape and function.*

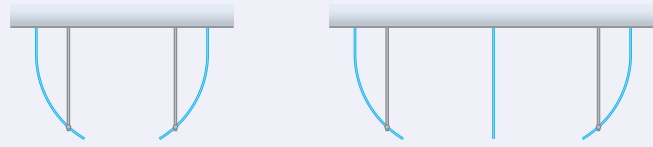

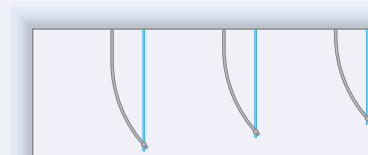
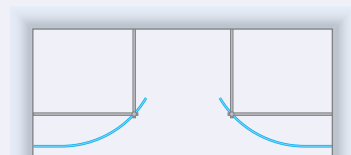

YNVENTA





Le chiusure doccia lineari sono disponibili in 3 dimensioni:

cm 74, 84, 94

*Straight shower enclosures available in 3 dimensions:*

*cm 74, 84, 94*

Le chiusure doccia curve sono disponibili in 1 dimensione:

cm 86,7x37,2 (r 76)

*Curved shower enclosures available in one version only:*

*cm 86,7x37,2 (r 76)*





## YNCONTRA

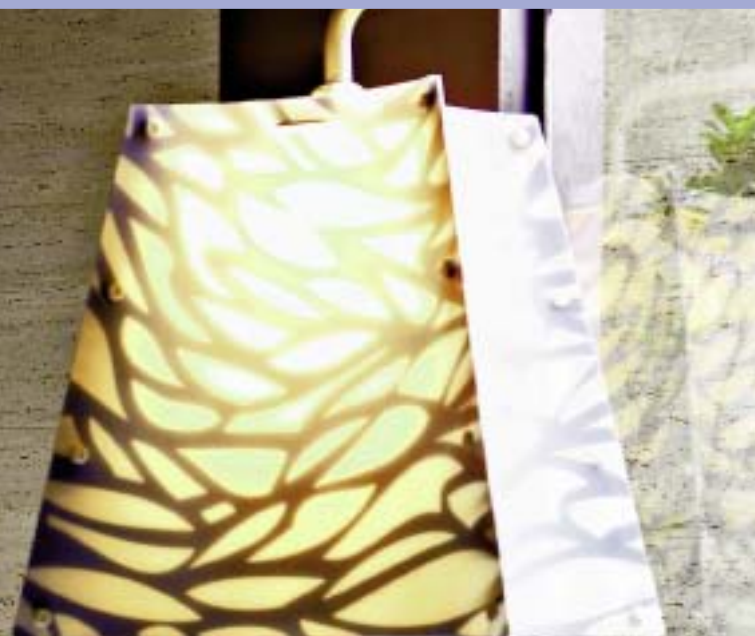

Concepita in esclusiva per i modelli Young Collection Project, Yncontra trasforma la vasca in un combinato multifunzione: con la massima rapidità e semplicità di installazione. Inoltre la porta si apre totalmente verso l'esterno, agevolando l'accessibilità e i movimenti all'interno.

*Conceived exclusively for the Young Collection Project models, the Yncontra transforms the bath into a multifunction combined model in the wink of an eye and with simplicity of installation. Furthermore, the door opens fully outwards, for easy access and inside movements.*





## RUBINETTERIA BRASSWARE



### **FUNZIONALITÀ CHE FA TENDENZA**

La rubinetteria è al tempo stesso un elemento distintivo dell'arredo e un componente funzionale del bagno. Due valenze che trovano una nuova sintesi, nella rubinetteria Young. Forme dinamiche e fluenti, superfici morbide e tondeggianti, per un'attualità che non passa di moda. Tecnologie evolute e durevoli, per donare a lungo il piacere della comodità e dell'affidabilità. Superfici perfettamente lisce, per trasmettere alla vista e al tatto il prestigio di una perfetta realizzazione e, al tempo stesso, rendere facile la pulizia e perfetta l'igiene. Tutto questo in armonia con il design dei modelli Young Collection Project e con lo spirito di un ambiente bagno speciale, in ogni dettaglio: il tuo.

### **TRENDY FUNCTIONALITY**

*Tapware is at the same time a distinctive furnishing element and a functional bathroom component. Two qualities that find a new synthesis in the Young tapware. Dynamic and flowing shapes, gently rounded surfaces, for a fashion that never fades. Evolved and durable technologies to give you the pleasure of comfort and reliability for a very long time. Absolutely smooth surfaces, to transmit the prestige of perfection to the sight and to the touch while simultaneously make cleaning easy and hygiene perfect. All this is in harmony with the design of the Young Collection Project and with the spirit of bathroom that is special in every detail: yours.*



Rubinetteria vasca  
Bath tapware



Bordo Vasca 4 Fori. Miscelatore Bicomando.  
Deviatore a due vie. Doccino a mano di serie.

*4 Hole Tub Edge. Two tap mixer. Two-way  
diverter. Standard hand-held showerhead.*

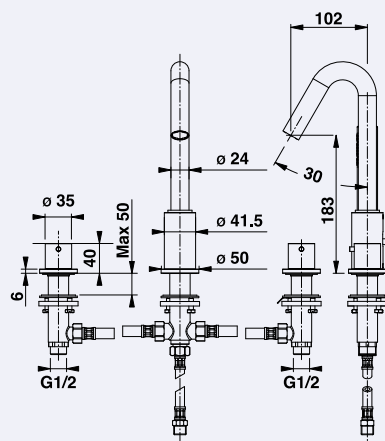

Rubinetteria vasca  
Bath tapware



Monocomando per vasca  
con doccino a mano di serie.

*Single tap for the tub  
with standard hand-held showerhead.*

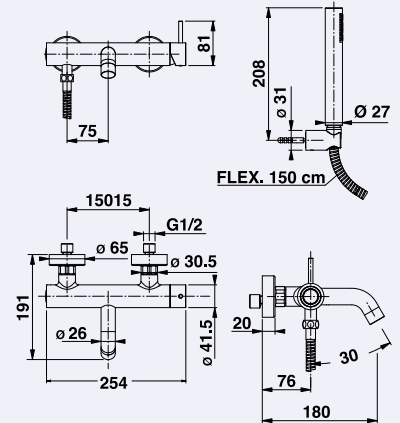

Rubinetteria lavabo  
Washbasin tapware



Miscelatore monocomando per lavabo.  
Da abbinare a clic-clac.

*Single tap mixer for the basin. To match with  
clic-clac waste.*

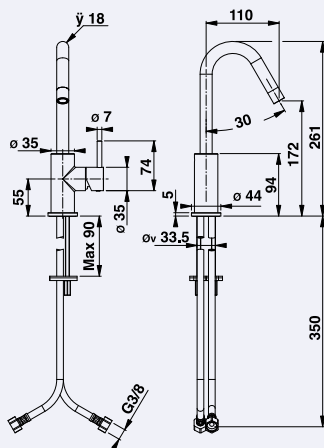

Rubinetteria lavabo  
Washbasin tapware



Miscelatore monocomando  
lavabo ad incasso. Da abbinare a clic-clac.

*Built-in single tap basin mixer.  
To match with clic-clac waste.*

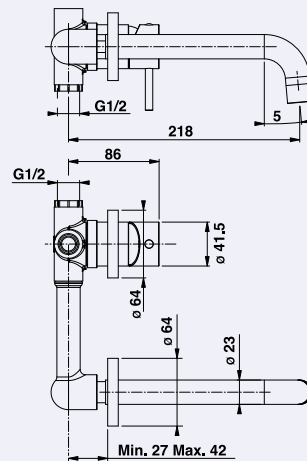

Rubinetteria bidet  
Bidet tapware



Miscelatore monocomando per bidet.  
Da abbinare a clic-clac.

*Single tap mixer for the bidet. To match with  
clic-clac waste.*

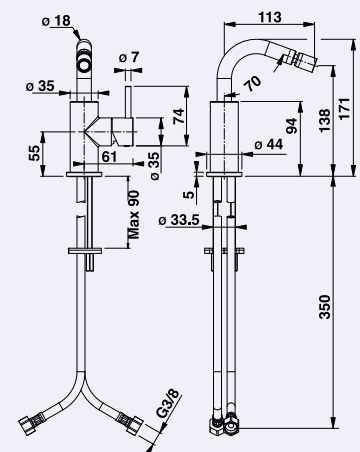

Rubetteria box  
Shower enclosure tapware



Monocomando per incasso su box doccia.  
Abbinabile a soffione pioggia o doccino mano.

*Built-in single tap for the shower. To be combined either with overhead shower or hand-held showerhead.*

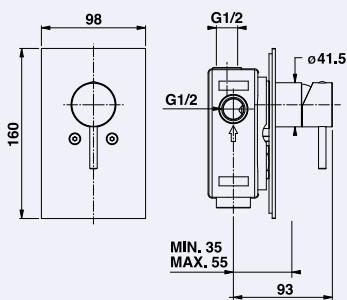

Rubetteria box  
Shower enclosure tapware



Monocomando per incasso su box doccia.  
Soffione Pieggià di serie.

*Single tap to be built-in the shower. Standard overhead showerhead.*

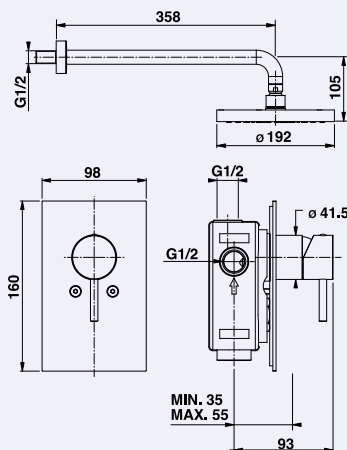

Rubetteria box  
Shower enclosure tapware



Monocomando per incasso su box doccia.  
Doccino a mano di serie. Asta saliscendi di serie.

*Single tap to be built-in the shower. Standard hand-held showerhead. Standard slider rod.*

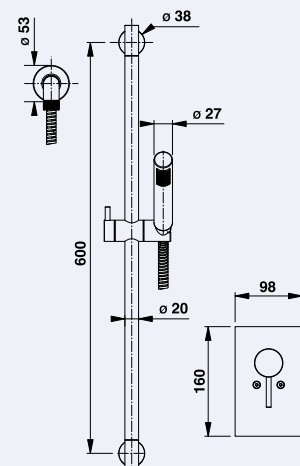

Rubinetteria box  
Shower enclosure tapware



Monocomando per incasso su box doccia o vasca. Deviatore a due vie.

Single tap to be built-in the shower or tub. Two-way diverter.

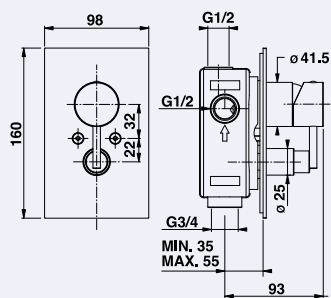

Rubinetteria box  
Shower enclosure tapware



Monocomando per incasso su box doccia o vasca. Deviatore a due vie, soffione pioggia di serie. Doccino a mano di serie, asta saliscendi di serie.

Single tap to be built-in the shower or tub. Two-way diverter, standard overhead showerhead. Standard hand-held showerhead, standard slider rod.

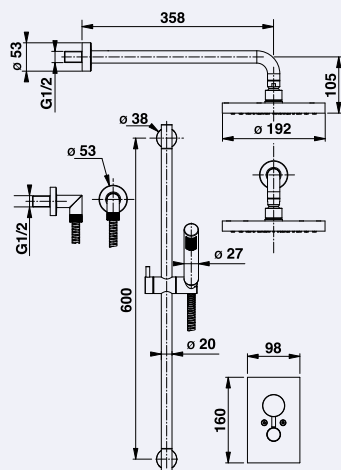

Rubinetteria box  
Shower enclosure tapware



Miscelatore Monocomando doccia esterno. Doccino a mano di serie. Asta saliscendi di serie.

Single Tap Mixer for shower. Standard hand-held showerhead. Standard slider rod.

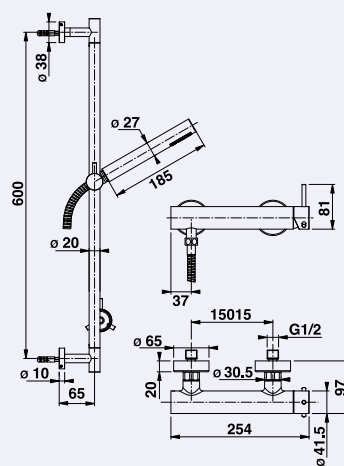



	JET	AIR	DUO		
<b>FUNZIONI</b>				<b>FUNCTIONS</b>	
Idroterapiche				Hydrotherapy	
Bocchette idro rotanti Twist Jet				Rotating hydromassage Twist Jet	
Bocchette idro fisse Hidro Jet				Fixed hydromassage Hydro Jet	
Air				Air	
<b>DOTAZIONI</b>				<b>ACCESSORIES</b>	
RUBINETTERIA YOUNG				YOUNG TAPWARE	
Doccetta/erogatore con deviazione automatica				Handheld shower/spout with automatic diverter	
Manopole acqua calda/fredda				Hot/cold water knob	
Comando piletta (alza/abbassa la piletta)				Waste control (raises/lowers the waste)	
<b>LUMINA</b>				<b>LUMINA</b>	
On/Off Jet				On/Off Jet	
Regolazione Jet				Jet regulation	
On/Off Air				On/Off Air	
Regolazione Air ( +/- )				Air regulation ( +/- )	
Tasto sanitizzazione				Sanitizing button	
<b>VASCA</b>				<b>BATHTUB</b>	
Bocchette Jet	8		8	Jet	
Bocchette Air		12	12	Air jets	
Sanitizzazione				Sanitizing system	
Erogazione dal troppo pieno				Overflow drain	
<b>Drenaggio impianto Blower</b>				<b>Blower system drainage</b>	
Scarico				Drain	
Poggiatesta				Headrest	
<b>VERSIONI DISPONIBILI</b>				<b>VERSIONS OFFER</b>	
Sx				Lh	
Dx				Rh	
<b>FINITURE</b>				<b>FINISHES</b>	
<b>FINITURE RUBINETTERIA</b>				<b>TAPS FINISHES</b>	
Cromo				Chrome	
<b>PANNELLI</b>				<b>PANELS</b>	
Laterale				Side panel	
Frontale				Front panel	
		170x70	170x75		
<b>CARATTERISTICHE</b>				<b>SPECIFICATIONS</b>	
<b>DIMENSIONI ESTERNE</b>				<b>EXTERNAL DIMENSION</b>	
Lunghezza cm	170	170	cm	Length	
Larghezza cm	70	75	cm	Width	
Altezza cm	60	60	cm	Height	
<b>DIMENSIONI INTERNE</b>				<b>INSIDE DIMENSION</b>	
Profondità vasca cm	45	45	cm	Depth of bathtub	
Lunghezza al bordo superiore cm	160	160	cm	Length at top edge	
Lunghezza alle bocchette cm	130	130	cm	Length at fittings	
Larghezza centrale al bordo superiore cm	57	62	cm	Central width at top edge	
Peso netto vasca Kg	59	60	Kg	Bathtub net weight	
Carico sul pavimento (al troppo pieno) Kg/m²	220	219	Kg/m²	Load on floor (at the overflow level)	
Volume d'acqua (al troppo pieno) Litri	220	235	Litres	Water volume (at the overflow level)	
Quantità media d'acqua per l'idromassaggio Litri	150	175	Litres	Average water quantity for hydromassage	
Max potenza assorbita kW	0,7	0,7	1,4	kW	Max. absorbed power
Alimentazione elettrica Volt	220/240			Volt	Electric power supply
Hz	50			Hz	

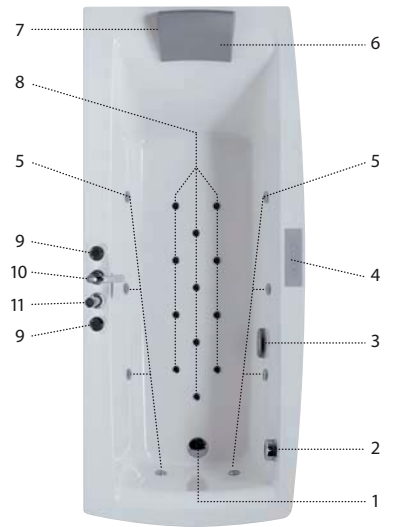

- 1 Scarico .  
Drain.
- 2 Troppo pieno .  
Overflow.
- 3 Bocchetta di aspirazione .  
Suction inlet.
- 4 Display Lumina .  
Lumina display.
- 5 Bocchette Jet (8).  
Jets (8).
- 6 Poggiatesta .  
Soft headrest.
- 7 Sportellino di riempimento liquido di sanitizzazione .  
Lid for adding sanitizing fluid.
- 8 Bocchette Air (12).  
Air jets (12).
- 9 Manopole acqua calda/fredda .  
Hot/cold water knob.
- 10 Erogatore con deviazione automatica (doccetta/erogatore) .  
Spout with automatic diverter (shower/spout).
- 11 Doccetta manuale estraibile .  
Hand-held shower.

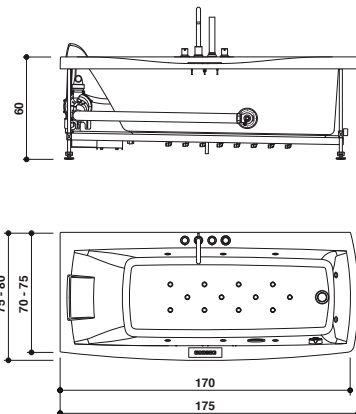

Vista versione Sx - Left hand version view

Plus - Highlight   Optional - Optional   Di serie - Included  





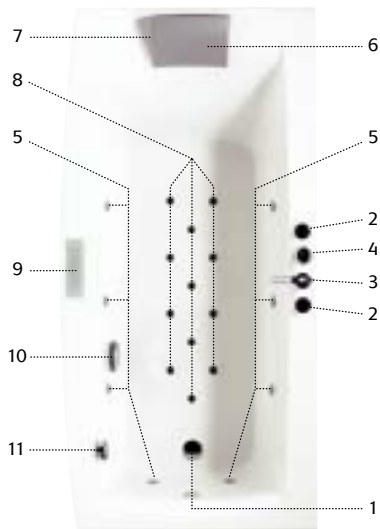

- 1 Scarico.  
*Drain.*
- 2 Manopole acqua calda/fredda.  
*Hot/cold water knob.*
- 3 Erogatore con deviazione automatica (doccetta/erogatore).  
*Spout with automatic diverter (shower/spout).*
- 4 Doccetta manuale estraibile.  
*Hand-held shower.*
- 5 Bocchette Jet (8).  
*Jets (8).*
- 6 Poggiatesta.  
*Soft headrest.*
- 7 Sportellino di riempimento liquido di sanizzazione.  
*Lid for adding sanitizing fluid.*
- 8 Bocchette Air (12).  
*Air Jets (12).*
- 9 Display Lumina.  
*Lumina display.*
- 10 Bocchetta di aspirazione.  
*Suction inlet.*
- 11 Troppo pieno.  
*Overflow.*

	JET	AIR	DUO	
<b>FUNZIONI</b>				
<b>Idroterapiche</b>				
Bocchette idro rotanti Twist Jet				<b>FUNCTIONS</b> <i>Rotating hydromassage Twist Jet</i>
Bocchette idro fisse Hidro Jet				<i>Fixed hydromassage Hydro Jet</i>
Air				<i>Air</i>
<b>DOTAZIONI</b>				
<b>RUBINETTERIA YOUNG</b>				
Doccetta/erogatore con deviazione automatica				<b>ACCESSORIES</b> <i>Handheld shower/spout with automatic diverter</i>
Manopole acqua calda/fredda				<i>Hot/cold water knob</i>
Comando piletta (alza/abbassa la piletta)				<i>Waste control (raises/lowers the waste)</i>
<b>LUMINA</b>				
On/Off Jet				<i>On/Off Jet</i>
Regolazione Jet				<i>Jet regulation</i>
On/Off Air				<i>On/Off Air</i>
Regolazione Air ( +/- )				<i>Air regulation (+/-)</i>
Tasto sanizzazione				<i>Sanitizing button</i>
<b>VASCA</b>				
Bocchette Jet	8		8	<i>Jet</i>
Bocchette Air		12	12	<i>Air jets</i>
Sanizzazione				<i>Sanitizing system</i>
Erogazione dal troppo pieno				<i>Overflow drain</i>
<b>Drenaggio impianto Blower</b>				
Scarico				<i>Drain</i>
Poggiatesta				<i>Headrest</i>
<b>VERSIONI DISPONIBILI</b>				
Sx				<i>Lh</i>
Dx				<i>Rh</i>
<b>FINITURE</b>				
<b>FINITURE RUBINETTERIA</b>				
Cromo				<i>Chrome</i>
<b>PANNELLI</b>				
Laterale				<i>Side panel</i>
Frontale				<i>Front panel</i>
<b>CARATTERISTICHE</b>				
<b>DIMENSIONI ESTERNE</b>				
Lunghezza	cm	170		<i>cm Length</i>
Larghezza	cm	78/84		<i>cm Width</i>
Altezza	cm	60		<i>cm Height</i>
<b>DIMENSIONI INTERNE</b>				
Profondità vasca	cm	45		<i>cm Depth of bathtub</i>
Lunghezza al bordo superiore	cm	150		<i>cm Length at top edge</i>
Lunghezza alle bocchette	cm	120		<i>cm Length at fittings</i>
Larghezza centrale al bordo superiore	cm	64		<i>cm Central width at top edge</i>
Peso netto vasca	Kg	64		<i>Kg Bathtub net weight</i>
Carico sul pavimento (al troppo pieno)	Kg/m <sup>2</sup>	225		<i>Kg/m<sup>2</sup> Load on floor (at the overflow level)</i>
Volume d'acqua (al troppo pieno)	Litri	240		<i>Litres Water volume (at the overflow level)</i>
Quantità media d'acqua per l'idromassaggio	Litri	160		<i>Litres Average water quantity for hydromassage</i>
Max potenza assorbita	kW	0.7   0.7   1.4		<i>kW Max. absorbed power</i>
Alimentazione elettrica	Volt	220/240		<i>Volt Electric power supply</i>
	Hz	50		<i>Hz</i>

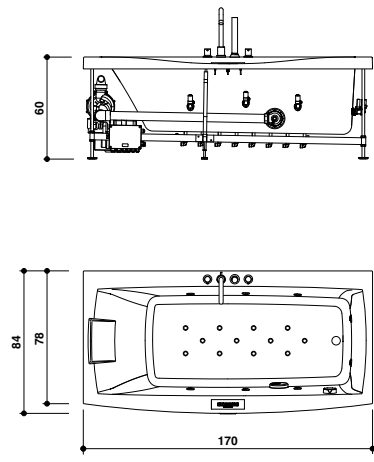

Vista versione Sx - Left hand version view

	JET	AIR	DUO	
<b>FUNZIONI</b>				<b>FUNCTIONS</b>
<b>Idroterapiche</b>				<b>Hydrotherapy</b>
Bocchette idro rotanti Twist Jet				Rotating hydromassage Twist Jet
Bocchette idro fisse Hidro Jet				Fixed hydromassage Hydro Jet
Air				Air
<b>DOTAZIONI</b>				<b>ACCESSORIES</b>
<b>RUBINETTERIA YOUNG</b>				<b>YOUNG TAPWARE</b>
Doccetta/erogatore con deviazione automatica				Handheld shower/spout with automatic diverter
Manopole acqua calda/fredda				Hot/cold water knob
Comando piletta (alza/abbassa la piletta)				Waste control (raises/lowers the waste)
<b>LUMINA</b>				<b>LUMINA</b>
On/Off Jet				On/Off Jet
Regolazione Jet				Jet regulation
On/Off Air				On/Off Air
Regolazione Air ( +/- )				Air regulation (+/-)
Tasto sanitizzazione				Sanitizing button
<b>VASCA</b>				<b>BATHTUB</b>
Bocchette Jet	8		8	Jet
Bocchette Air		11	11	Air jets
Sanitizzazione				Sanitizing system
Erogazione dal troppo pieno				Overflow drain
<b>Drenaggio impianto Blower</b>				<b>Blower system drainage</b>
Scarico				Drain
Poggiatesta	2	2	2	Headrest
<b>VERSIONI DISPONIBILI</b>				<b>VERSIONS OFFER</b>
Unica				Single
<b>FINITURE</b>				<b>FINISHES</b>
<b>FINITURE RUBINETTERIA</b>				<b>TAPS FINISHES</b>
Cromo				Chrome
<b>PANNELLI</b>				<b>PANELS</b>
Laterale				Side panel
Frontale				Front panel
<b>CARATTERISTICHE</b>				<b>SPECIFICATIONS</b>
<b>DIMENSIONI ESTERNE</b>				<b>EXTERNAL DIMENSION</b>
Lunghezza	cm	180	cm	Length
Larghezza	cm	78/88	cm	Width
Altezza	cm	60	cm	Height
<b>DIMENSIONI INTERNE</b>				<b>INSIDE DIMENSION</b>
Profondità vasca	cm	45	cm	Depth of bathtub
Lunghezza al bordo superiore	cm	168	cm	Length at top edge
Lunghezza alle bocchette	cm	127	cm	Length at fittings
Larghezza centrale al bordo superiore	cm	58	cm	Central width at top edge
Peso netto vasca	Kg	63	Kg	Bathtub net weight
Carico sul pavimento (al troppo pieno)	Kg/m <sup>2</sup>	214	Kg/m <sup>2</sup>	Load on floor (at the overflow level)
Volume d'acqua (al troppo pieno)	Litri	260	Litres	Water volume (at the overflow level)
Quantità media d'acqua per l'idromassaggio	Litri	160	Litres	Average water quantity for hydromassage
Max potenza assorbita	kW	0,7   0,7   1,4	kW	Max. absorbed power
Alimentazione elettrica	Volt	220/240	Volt	Electric power supply
	Hz	50	Hz	

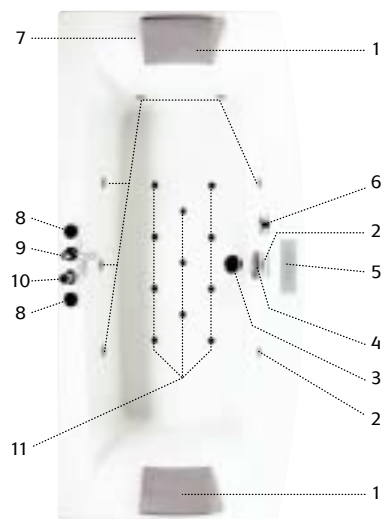

- 1 Poggiatesta.  
Soft headrest.
- 2 Bocchette Jet (8).  
Jets (8).
- 3 Scarico.  
Drain.
- 4 Bocchetta di aspirazione.  
Suction inlet.
- 5 Display Lumina.  
Lumina display.
- 6 Troppo pieno.  
Overflow.
- 7 Sportellino di riempimento liquido di sanitizzazione.  
Lid for adding sanitizing fluid.
- 8 Manopole acqua calda/fredda.  
Hot/cold water knob.
- 9 Erogatore con deviazione automatica (doccetta/erogatore).  
Spout with automatic diverter (shower/spout).
- 10 Doccetta manuale estraibile.  
Hand-held shower.
- 11 Bocchette Air (12).  
Air Jets (12).

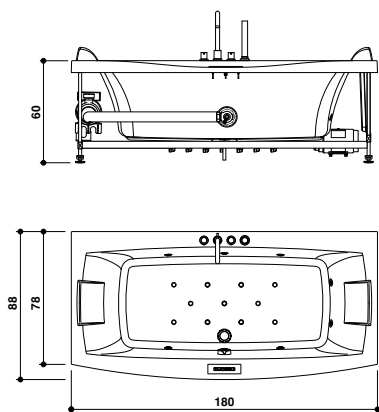

Versione unica - Single version

Plus - Highlight  Optional - Optional  Di serie - Included



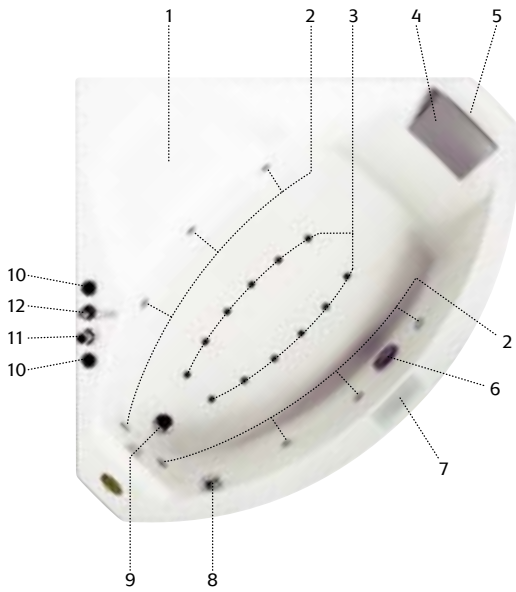

- 1 Seduta.  
*Seat.*
- 2 Bocchette Jet (8).  
*Jets (8).*
- 3 Bocchette Air (12).  
*Air Jets (12).*
- 4 Poggiatesta.  
*Soft headrest.*
- 5 Sportellino di riempimento liquido di sanitizzazione.  
*Lid for adding sanitizing fluid.*
- 6 Bocchetta di aspirazione.  
*Suction inlet.*
- 7 Display Lumina.  
*Lumina display.*
- 8 Troppo pieno.  
*Overflow.*
- 9 Scarico.  
*Drain.*
- 10 Manopole acqua calda/fredda.  
*Hot/cold water knob.*
- 11 Doccetta manuale estraibile.  
*Hand-held shower.*
- 12 Erogatore con deviazione automatica (doccetta/erogatore).  
*Spout with automatic diverter (shower/spout).*

	JET	AIR	DUO	
<b>FUNZIONI</b>				<b>FUNCTIONS</b>
Idroterapiche				<b>Hydrotherapy</b>
Bocchette idro rotanti Twist Jet				<i>Rotating hydromassage Twist Jet</i>
Bocchette idro fisse Hidro Jet				<i>Fixed hydromassage Hydro Jet</i>
Air				<i>Air</i>
<b>DOTAZIONI</b>				<b>ACCESSORIES</b>
<b>RUBINETTERIA YOUNG</b>				<b>YOUNG TAPWARE</b>
Doccetta/erogatore con deviazione automatica				<i>Handheld shower/spout with automatic diverter</i>
Manopole acqua calda/fredda				<i>Hot/cold water knob</i>
Comando piletta (alza/abbassa la piletta)				<i>Waste control (raises/lowers the waste)</i>
<b>LUMINA</b>				<b>LUMINA</b>
On/Off Jet				<i>On/Off Jet</i>
Regolazione Jet				<i>Jet regulation</i>
On/Off Air				<i>On/Off Air</i>
Regolazione Air (+/-)				<i>Air regulation (+/-)</i>
Tasto sanitizzazione				<i>Sanitizing button</i>
<b>VASCA</b>				<b>BATHTUB</b>
Bocchette Jet	8		8	<i>Jet</i>
Bocchette Air		12	12	<i>Air jets</i>
Sanitizzazione				<i>Sanitizing system</i>
Erogazione dal troppo pieno				<i>Overflow drain</i>
<b>Drenaggio impianto Blower</b>				<b>Blower system drainage</b>
Scarico				<i>Drain</i>
Poggiatesta				<i>Headrest</i>
<b>VERSIONI DISPONIBILI</b>				<b>VERSIONS OFFER</b>
Unica				<i>Single</i>
<b>FINITURE</b>				<b>FINISHES</b>
<b>FINITURE RUBINETTERIA</b>				<b>TAPS FINISHES</b>
Cromo				<i>Chrome</i>
<b>PANNELLI</b>				<b>PANELS</b>
Frontale				<i>Front panel</i>
<b>CARATTERISTICHE</b>				<b>SPECIFICATIONS</b>
<b>DIMENSIONI ESTERNE</b>				<b>EXTERNAL DIMENSION</b>
Lunghezza cm		130/145	cm	<i>Length</i>
Larghezza cm		130/145	cm	<i>Width</i>
Altezza cm		60	cm	<i>Height</i>
<b>DIMENSIONI INTERNE</b>				<b>INSIDE DIMENSION</b>
Profondità vasca cm		45	cm	<i>Depth of bathtub</i>
Lunghezza al bordo superiore cm		155	cm	<i>Length at top edge</i>
Lunghezza alle bocchette cm		125	cm	<i>Length at fittings</i>
Larghezza centrale al bordo superiore cm		87	cm	<i>Central width at top edge</i>
Peso netto vasca Kg		72	Kg	<i>Bathtub net weight</i>
Carico sul pavimento (al troppo pieno) Kg/m <sup>2</sup>		246	Kg/m <sup>2</sup>	<i>Load on floor (at the overflow level)</i>
Volume d'acqua (al troppo pieno) Litri		300	Litres	<i>Water volume (at the overflow level)</i>
Quantità media d'acqua per l'idromassaggio Litri		175	Litres	<i>Average water quantity for hydromassage</i>
Max potenza assorbita kW	0,7	0,7	1,4	<i>kW Max. absorbed power</i>
Alimentazione elettrica Volt		220/240	Volt	<i>Electric power supply</i>
Hz		50	Hz	

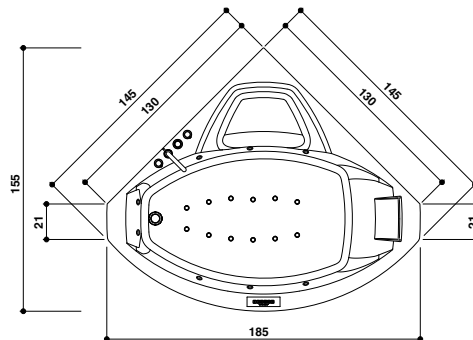
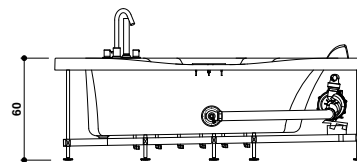

Versione unica - Single version

	TT	TB	
<b>FUNZIONI</b>			<b>FUNCTIONS</b>
<b>Idroterapiche</b>			<b>Hydrotherapy</b>
Idromassaggio verticale e dorsale	4+4	4+4	Vertical and back hydromassage
Doccia Spray			Spray shower head
Doccia Cascata			Shower Cascade
Bagno turco con clima			Steam bath with Clima
<b>Sensoriali</b>			<b>Sensory</b>
Aromaterapia			Aromatherapy
<b>DOTAZIONI</b>			<b>ACCESSORIES</b>
Bocchette idromassaggio verticale	4+4	4+4	Vertical hydromassage jets
Doccetta manuale			Hand held shower head
Soffione Spray			Spray shower head
Cascata			Cascade
Deviatore funzioni box			Shower Diverter
Miscelatore monocomando	A	A	Single-lever mixer tap
Miscelatore termostatico	B	B	Thermostatic mixer
Generatore vapore incasso			Built-in steam generator
Cristalli a muro (bianchi)			Glass wall panels (white)
Piatto doccia ribassato (Techstone)			Lowered shower tray (Techstone)
Pedana (Techstone)			Duckboard (Techstone)
Seduta ribaltabile			Adjustable seat
Mensola			Shelf
Tettuccio opalino autodrenante			Self-draining opaline roof
Cristal Clear by Jacuzzi®			Crystal Clear by Jacuzzi®
Contentore olii essenziali	2		Container for aromatic essence
Membrane anticalcare per erogatori			Limescale-prevention membrane for spouts
Sistema di decalcificazione			Electronic descaling system
Maniglia			Handle
Uscita vapore	2		Steam outlet
<b>VERSIONI DISPONIBILI</b>			<b>VERSIONS OFFER</b>
SX			Lh
Dx			Rh
<b>FINITURE</b>			<b>FINISHES</b>
<b>FINITURE RUBINETTERIA</b>			<b>TAPS FINISHES</b>
Cromo			Chrome
<b>FINITURE COLONNA</b>			<b>COLUMN FINISHES</b>
Alluminio micropallinato			Peened aluminium
Rosso Acero Spazzolato			Brushed Maple Red
Bianco			White
<b>CARATTERISTICHE</b>			<b>SPECIFICATIONS</b>
Lunghezza	cm 90	90	cm Length
Larghezza	cm 70	70	cm Width
Altezza	cm 226	222	cm Height
Altezza minima di installazione	cm 235	235	cm Minimal installation height
Incasso a pavimento (piletta)	mm 80	80	mm Built into the floor (waste)
Peso netto	Kg 155	150	Kg Net weight
Max potenza assorbita	kW 2,5		kW Power absorbtion
Alimentazione elettrica	Volt 220/240		Volt Electric power
	Hz 50		Hz

A= Allestimento 1 - Preparation 1  
B= Allestimento 2 - Preparation 2

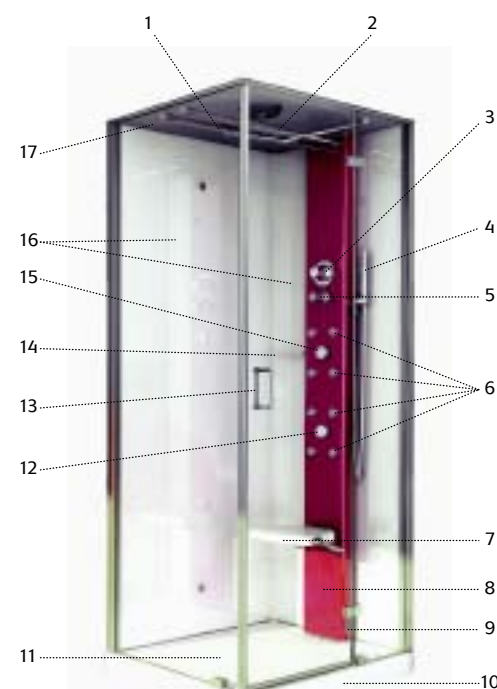

- 1 Soffione Spray. Spray shower head.
- 2 Cascata. Cascade.
- 3 Deviatore funzioni box. Shower Diverter.
- 4 Doccetta manuale. Hand held shower head.
- 5 Miscelatore termostatico. Thermostatic mixer.
- 6 Bocchette idromassaggio verticale (4+4). Vertical hydromassage jets (4+4).
- 7 Seduta ribaltabile. Adjustable seat.
- 8 Generatore vapore incasso. Built-in steam generator.
- 9 Contenitore olii essenziali, uscita vapore. Container for aromatic essence, steam outlet.
- 10 Piatto doccia ribassato (Techstone). Lowered shower tray (Techstone).
- 11 Pedana (Techstone). Duckboard (Techstone).
- 12 Sistema di decalcificazione. Electronic descaling system.
- 13 Maniglia. Handle.
- 14 Ripiano d'appoggio. Shelf.
- 15 Controllo generatori. Generator control.
- 16 Cristalli a muro (bianchi). Glass wall panels (white).
- 17 Tettuccio opalino autodrenante. Self-draining opaline roof.

	Alluminio micropallinato Peened aluminium
	Rosso Acero spazzolato Brushed Maple Red
	Bianco White

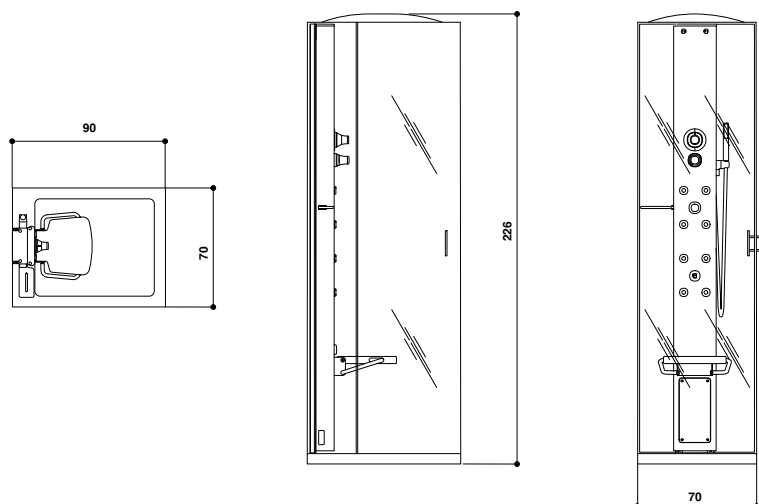

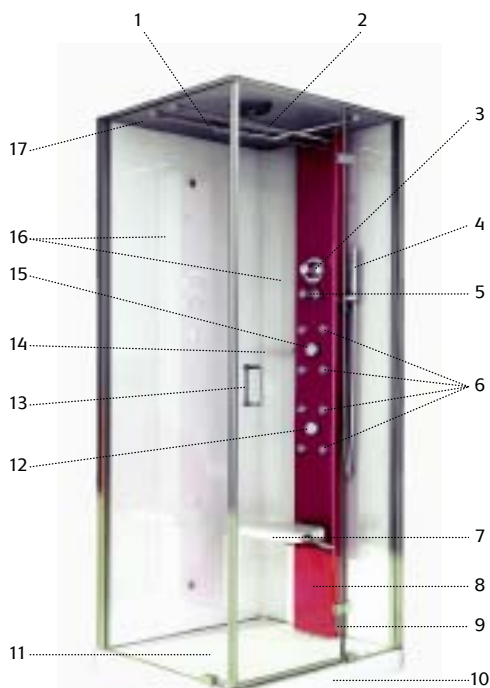

- 1 Soffione Spray.  
*Spray shower head.*
- 2 Cascata.  
*Cascade.*
- 3 Deviatore funzioni box.  
*Shower Diverter.*
- 4 Doccetta manuale.  
*Hand held shower head.*
- 5 Miscelatore termostatico.  
*Thermostatic mixer.*
- 6 Bocchette idromassaggio verticale (4+4).  
*Vertical hydromassage jets (4+4).*
- 7 Seduta ribaltabile.  
*Adjustable seat.*
- 8 Generatore vapore incasso.  
*Built-in steam generator.*
- 9 Contenitore olii essenziali, uscita vapore.  
*Container for aromatic essence, steam outlet.*
- 10 Piatto doccia ribassato (Techstone).  
*Lowered shower tray (Techstone).*
- 11 Pedana (Techstone).  
*Duckboard (Techstone).*
- 12 Sistema di decalcificazione.  
*Electronic descaling system.*
- 13 Maniglia.  
*Handle.*
- 14 Ripiano d'appoggio.  
*Shelf.*
- 15 Controllo generatore.  
*Generator control.*
- 16 Cristalli a muro (bianchi).  
*Glass wall panels (white).*
- 17 Tettuccio opalino autodrenante.  
*Self-draining opaline roof.*

- Alluminio micropallinato  
*Peened aluminium*
- Rosso Acero spazzolato  
*Brushed Maple Red*
- Bianco  
*White*



	TT	TB	
<b>FUNZIONI</b>			<b>FUNCTIONS</b>
<b>Idroterapiche</b>			<b>Hydrotherapy</b>
Idromassaggio verticale e dorsale	4+4	4+4	Vertical and back hydromassage
Doccia Spray			Spray shower head
Doccia Cascata			Shower Cascade
Bagno turco con clima			Steam bath with Clima
<b>Sensoriali</b>			<b>Sensory</b>
Aromaterapia			Aromatherapy
<b>DOTAZIONI</b>			<b>ACCESSORIES</b>
Bocchette idromassaggio verticale	4+4	4+4	Vertical hydromassage jets
Doccetta manuale			Hand held shower head
<b>Soffione Spray</b>			<b>Spray shower head</b>
<b>Cascata</b>			<b>Cascade</b>
Deviatore funzioni box			Shower Diverter
Miscelatore monocomando	A	A	Single-lever mixer tap
Miscelatore termostatico	B	B	Thermostatic mixer
<b>Generatore vapore incasso</b>			<b>Built-in steam generator</b>
Cristalli a muro (bianchi)			Glass wall panels (white)
Piatto doccia ribassato (Techstone)			Lowered shower tray (Techstone)
<b>Pedana (Techstone)</b>			<b>Duckboard (Techstone)</b>
<b>Seduta ribaltabile</b>			<b>Adjustable seat</b>
Mensola			Shelf
Tettuccio opalino autodrenante			Self-draining opaline roof
Cristal Clear by Jacuzzi®			Crystal Clear by Jacuzzi®
Contenitore olii essenziali	2		Container for aromatic essence
Membrane anticalcare per erogatori			Limescale-prevention membrane for spouts
Sistema di decalcificazione			Electronic descaling system
Maniglia			Handle
Uscita vapore	2		Steam outlet
<b>VERSIONI DISPONIBILI</b>			<b>VERSIONS OFFER</b>
SX			Lh
Dx			Rh
<b>FINITURE</b>			<b>FINISHES</b>
<b>FINITURE RUBINETTERIA</b>			<b>TAPS FINISHES</b>
Cromo			Chrome
<b>FINITURE COLONNA</b>			<b>COLUMN FINISHES</b>
Alluminio micropallinato			Peened aluminium
Rosso Acero Spazzolato			Brushed Maple Red
Bianco			White
A= Allestimento 1 - Preparation 1			
B= Allestimento 2 - Preparation 2			
<b>CARATTERISTICHE</b>			<b>SPECIFICATIONS</b>
Lunghezza	cm 100	100	cm Length
Larghezza	cm 75	75	cm Width
Altezza	cm 226	222	cm Height
Altezza minima di installazione	cm 235	235	cm Minimal installation height
Incasso a pavimento (pielletta)	mm 80	80	mm Built into the floor (waste)
Peso netto	Kg 171	165	Kg Net weight
Max potenza assorbita	kW 2,5		kW Power absorption
Alimentazione elettrica	Volt 220/240		Volt Electric power
	Hz 50		Hz

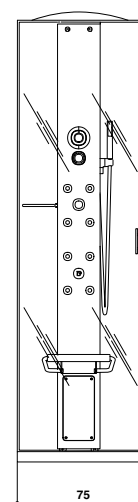
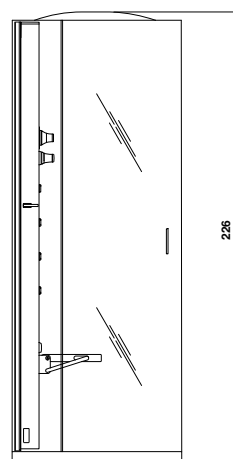
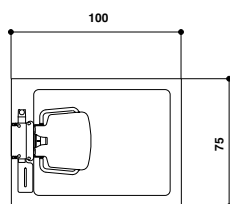

	TT	TB	
<b>FUNZIONI</b>			<b>FUNCTIONS</b>
<b>Idroterapiche</b>			<b>Hydrotherapy</b>
Idromassaggio verticale e dorsale	4+4	4+4	Vertical and back hydromassage
Doccia Spray			Spray shower head
Doccia Cascata			Shower Cascade
Bagno turco con clima			Steam bath with Clima
<b>Sensoriali</b>			<b>Sensory</b>
Aromaterapia			Aromatherapy
<b>DOTAZIONI</b>			<b>ACCESSORIES</b>
Bocchette idromassaggio verticale	4+4	4+4	Vertical hydromassage jets
Doccetta manuale			Hand held shower head
<b>Soffione Spray</b>			<b>Spray shower head</b>
Cascata			Cascade
Deviatore funzioni box			Shower Diverter
Miscelatore monocomando	A	A	Single-lever mixer tap
Miscelatore termostatico	B	B	Thermostatic mixer
<b>Generatore vapore incasso</b>			<b>Built-in steam generator</b>
Cristalli a muro (bianchi)			Glass wall panels (white)
Piatto doccia ribassato (Techstone)			Lowered shower tray (Techstone)
<b>Pedana (Techstone)</b>			<b>Duckboard (Techstone)</b>
<b>Seduta ribaltabile</b>			<b>Adjustable seat</b>
Mensola			Shelf
Tettuccio opalino autodrenante			Self-draining opaline roof
Cristal Clear by Jacuzzi®			Crystal Clear by Jacuzzi®
Contenitore olii essenziali	2		Container for aromatic essence
Membrane anticalcare per erogatori			Limescale-prevention membrane for spouts
Sistema di decalcificazione			Electronic descaling system
Maniglia			Handle
Uscita vapore	2		Steam outlet
<b>VERSIONI DISPONIBILI</b>			<b>VERSIONS OFFER</b>
Unica			Single
<b>FINITURE</b>			<b>FINISHES</b>
<b>FINITURE RUBINETTERIA</b>			<b>TAPS FINISHES</b>
Cromo			Chrome
<b>FINITURE COLONNA</b>			<b>COLUMN FINISHES</b>
Alluminio micropallinato			Peened aluminium
Rosso Acero Spazzolato			Brushed Maple Red
Bianco			White
<b>A= Allestimento 1 - Preparation 1</b>			
<b>B= Allestimento 2 - Preparation 2</b>			
<b>CARATTERISTICHE</b>			<b>SPECIFICATIONS</b>
Lunghezza	cm 90	cm 90	cm Length
Larghezza	cm 70	cm 70	cm Width
Altezza	cm 226	cm 222	cm Height
Altezza minima di installazione	cm 235	cm 235	cm Minimal installation height
Incasto a pavimento (piletta)	mm 80	mm 80	mm Built into the floor (waste)
Peso netto	Kg 157	Kg 151	Kg Net weight
Max potenza assorbita	kW 2.5	kW	kW Power absorption
Alimentazione elettrica	Volt 220/240	Volt	Volt Electric power
	Hz 50	Hz	Hz

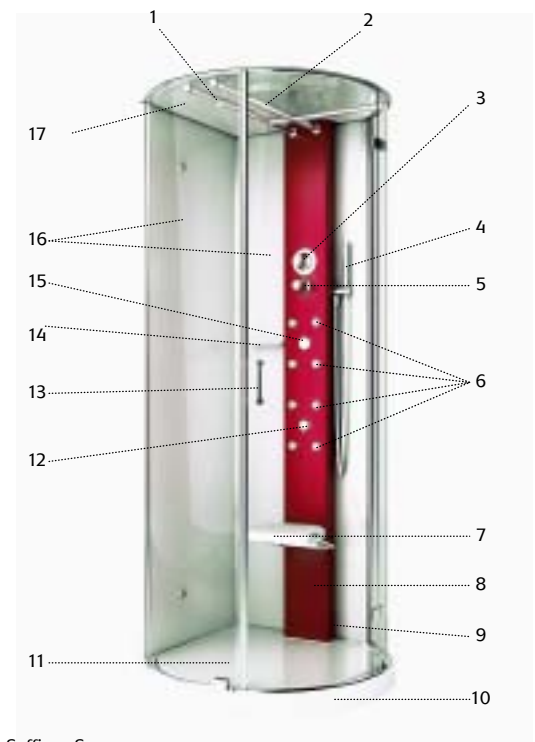

- 1 **Soffione Spray.**  
Spray shower head.
- 2 **Cascata.**  
Cascade.
- 3 **Deviatore funzioni box.**  
Shower Diverter.
- 4 **Doccetta manuale.**  
Hand held shower head.
- 5 **Miscelatore termostatico.**  
Thermostatic mixer.
- 6 **Bocchette idromassaggio verticale (4+4).**  
Vertical hydromassage jets (4+4).
- 7 **Seduta ribaltabile.**  
Adjustable seat.
- 8 **Generatore vapore incasso.**  
Built-in steam generator.
- 9 **Contenitore olii essenziali, uscita vapore.**  
Container for aromatic essence, steam outlet.
- 10 **Piatto doccia ribassato (Techstone).**  
Lowered shower tray (Techstone).
- 11 **Pedana (Techstone).**  
Duckboard (Techstone).
- 12 **Sistema di decalcificazione.**  
Electronic descaling system.
- 13 **Maniglia.**  
Handle.
- 14 **Ripiano d'appoggio.**  
Shelf.
- 15 **Controllo generatore.**  
Generator control.
- 16 **Cristalli a muro (bianchi).**  
Glass wall panels (white).
- 17 **Tettuccio opalino autodrenante.**  
Self-draining opaline roof.

	Alluminio micropallinato Peened aluminium
	Rosso Acero spazzolato Brushed Maple Red
	Bianco White

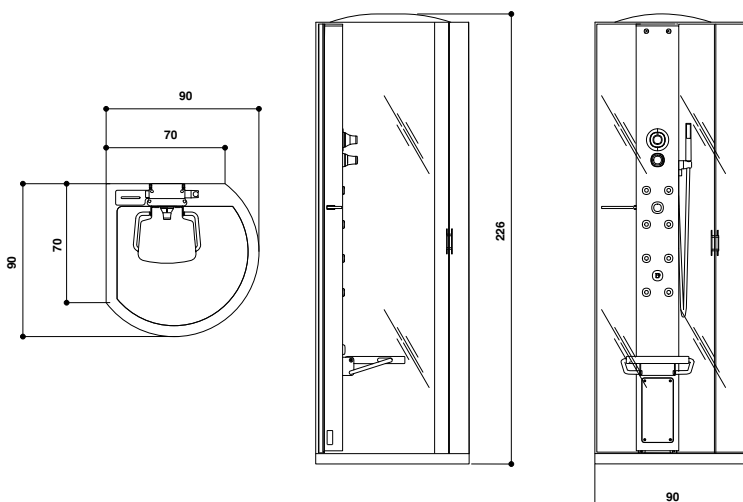

## REI

- 1 Soffione a pioggia.  
*Raindrop shower head.*
- 2 Colonna con profilo in Coeso.  
*Column with Coeso frame.*
- 3 Deviatore funzioni.  
*Shower diverter.*
- 4 Miscelatore termostatico.  
*Thermostatic mixer.*
- 5 Doccetta manuale.  
*Hand shower.*
- 6 Bocchette idromassaggio verticale.  
*Vertical hydromassage jets.*

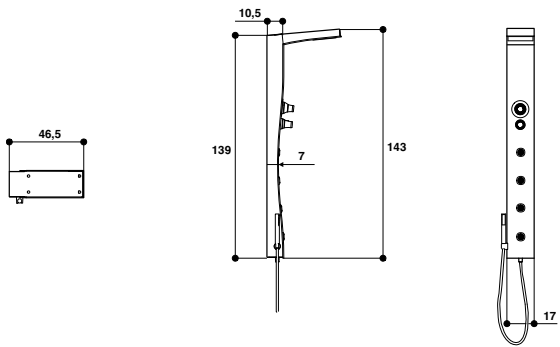
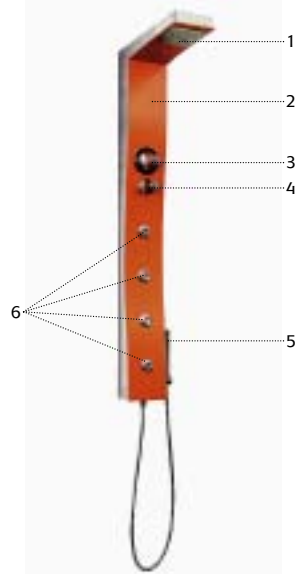
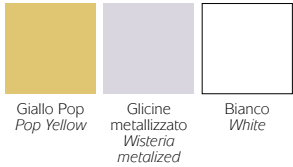

## NUDA

- 1 Soffione pioggia.  
*Raindrop shower head.*
- 2 Doccia scorrevole.  
*Sliding shower.*
- 3 Deviatore funzioni.  
*Shower diverter.*
- 4 Bocchette idromassaggio verticale.  
*Vertical hydromassage jets.*

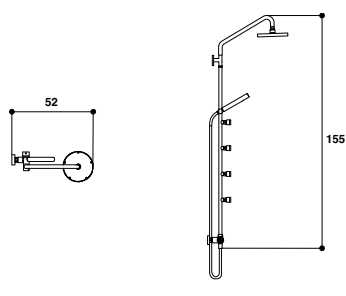
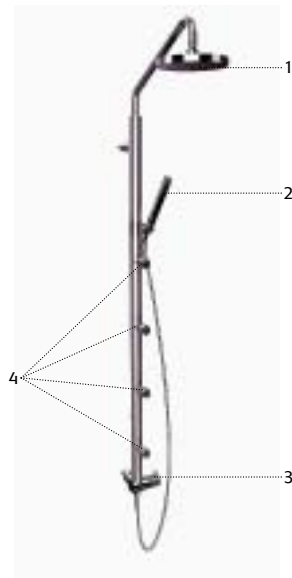

FUNZIONI		FUNCTIONS	
Idromassaggio verticale	4	Vertical hydromassage	
Soffione a pioggia		Raindrop shower head	
Doccetta manuale		Hand held shower head	
DOTAZIONI		ACCESSORIES	
Bocchette idromassaggio verticale	4	Vertical hydromassage jets	
Doccetta manuale		Hand shower	
Soffione a pioggia		Raindrop shower head	
Deviatore funzioni		Shower Diverter	
Miscelatore monocomando	A	Single-lever mixer tap	
Miscelatore termostatico	B	Thermostatic mixer	
Membrane anticalcare per erogatori		Limescale-prevention membrane for spouts	
VERSIONI DISPONIBILI		VERSIONS OFFER	
Installazione a parete		Back-to-wall installation	
Installazione ad angolo		Corner installation	
FINITURE		FINISHES	
<b>FINITURE RUBINETTERIA</b>		<b>TAPS FINISHES</b>	
Cromo		Chrome	
<b>FINITURE COLONNA</b>		<b>COLUMN FINISHES</b>	
Glicine metallizzato		Wisteria metalized	
Giallo Pop		Pop Yellow	
Bianco		White	
A= Allestimento 1- Preparation 1			
B= Allestimento 2- Preparation 2			
CARATTERISTICHE		SPECIFICATIONS	
Altezza	cm 143	cm Height	
Larghezza	cm 17	cm Width	
Peso netto	Kg 20	Kg Net weight	

FUNZIONI		FUNCTIONS	
Idromassaggio verticale	4	Vertical hydromassage	
Soffione a pioggia		Raindrop shower head	
Doccia scorrevole		Sliding shower	
DOTAZIONI		ACCESSORIES	
Bocchette idromassaggio verticale	4	Vertical hydromassage jets	
Doccia scorrevole		Sliding shower	
Soffione a pioggia		Raindrop shower head	
Deviatore funzioni		Shower Diverter	
Membrane anticalcare per erogatori		Limescale-prevention membrane for spouts	
VERSIONI DISPONIBILI		VERSIONS OFFER	
Attacco idrico in linea		In-line plumbing attachment	
FINITURE		FINISHES	
<b>FINITURE RUBINETTERIA</b>		<b>TAPS FINISHES</b>	
Cromo		Chrome	
<b>NB:</b> da abbinare a miscelatore esterno <b>NB:</b> To match with external unit (mixer)			
CARATTERISTICHE		SPECIFICATIONS	
Altezza	cm 155	cm Height	
Larghezza	cm 11	cm Width	
Peso netto	Kg 10,5	Kg Net weight	

## NUDA THERMAE

<b>FUNZIONI</b>	<b>FUNCTIONS</b>
Idromassaggio verticale	2 Vertical hydromassage
Soffione a pioggia	Raindrop shower head
Doccia scorrevole	Sliding shower
<b>DOTAZIONI</b>	<b>ACCESSORIES</b>
Bocchette idromassaggio verticale	2 Vertical hydromassage jets
Doccia scorrevole	Sliding shower
Soffione a pioggia	Raindrop shower head
Deviatore funzioni	Shower Diverter
Miscelatore termostatico	Thermostatic mixer
Membrane anticalcare per erogatori	Limescale-prevention membrane for spouts
<b>VERSIONI DISPONIBILI</b>	<b>VERSIONS OFFER</b>
Attacco idrico interasse 150 mm	Plumbing attachment, 150 mm c/c distance
<b>FINITURE</b>	<b>FINISHES</b>
<b>FINITURE RUBINETTERIA</b>	<b>TAPS FINISHES</b>
Cromo	Chrome
<b>CARATTERISTICHE</b>	<b>SPECIFICATIONS</b>
Altezza cm	150 cm Height
Larghezza cm	30 cm Width
Peso netto Kg	9 Kg Net weight

- 1 Soffione pioggia.  
Raindrop shower head.
- 2 Doccia scorrevole.  
Sliding shower.
- 3 Miscelatore termostatico.  
Thermostatic mixer.
- 4 Deviatore funzioni.  
Shower diverter.
- 5 Bocchette idromassaggio verticale.  
Vertical hydromassage jets.

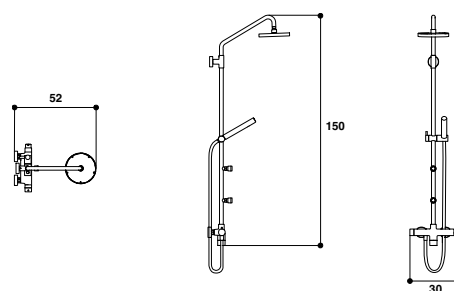
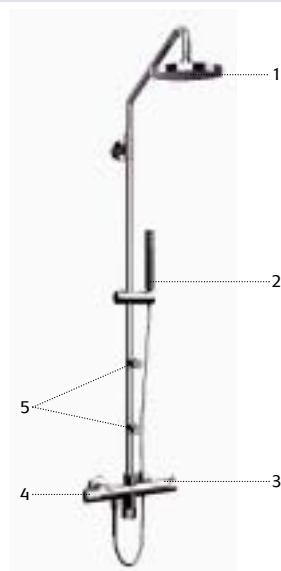

## NUDA ESSENTIAL

<b>FUNZIONI</b>	<b>FUNCTIONS</b>
Soffione a pioggia	Raindrop shower head
Doccia scorrevole	Sliding shower
<b>DOTAZIONI</b>	<b>ACCESSORIES</b>
Doccia scorrevole	Sliding shower
Soffione a pioggia	Raindrop shower head
Deviatore funzioni	Shower Diverter
Miscelatore termostatico	Thermostatic mixer
<b>VERSIONI DISPONIBILI</b>	<b>VERSIONS OFFER</b>
Attacco idrico interasse 150 mm	Plumbing attachment, 150 mm c/c distance
<b>FINITURE</b>	<b>FINISHES</b>
<b>FINITURE RUBINETTERIA</b>	<b>TAPS FINISHES</b>
Cromo	Chrome
<b>CARATTERISTICHE</b>	<b>SPECIFICATIONS</b>
Altezza cm	150 cm Height
Larghezza cm	30 cm Width
Peso netto Kg	7.5 Kg Net weight

- 1 Soffione pioggia.  
Raindrop shower head.
- 2 Doccia scorrevole.  
Sliding shower.
- 3 Miscelatore termostatico.  
Thermostatic mixer.
- 4 Deviatore funzioni.  
Shower diverter.

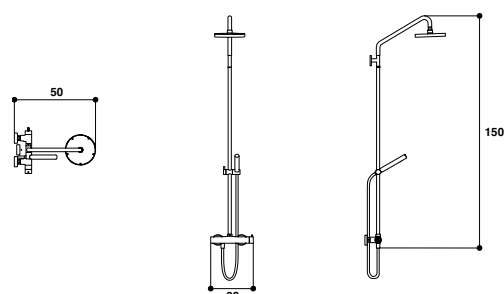



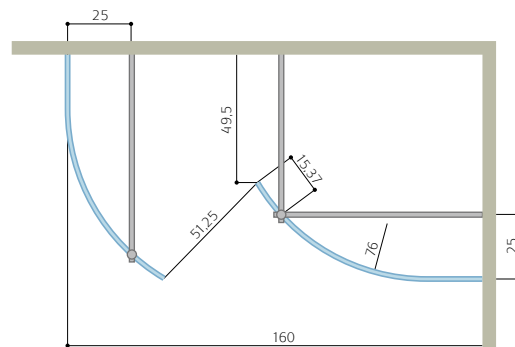
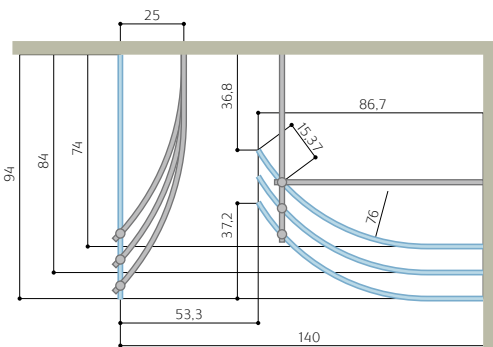
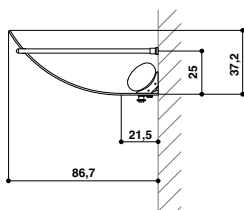
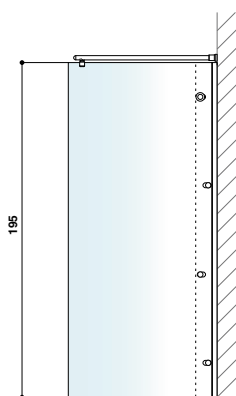
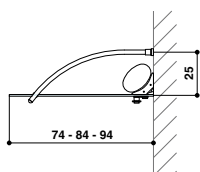
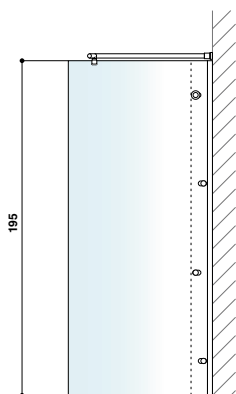

DOTAZIONI	ACCESSORIES
Sfumatura bianca	Shaded white
Cristal Clear by Jacuzzi® su ambo i lati	Cristal Clear by Jacuzzi® on both sides
Appendiaccappatoio	Bathrobe hook
Porta oggetti in cristallo	Glass toiletry shelf
Supporto a parete regolabile (+/- 15mm)	Adjustable wall support (+/- 15mm)

VERSIONI DISPONIBILI	VERSIONS OFFER
Versione unica	Single version

FINITURE	FINISHES
Cromo	Chrome

CARATTERISTICHE	SPECIFICATIONS
Altezza cm	195 cm Height
Larghezza cm	74 84 94 cm Width

DOTAZIONI	ACCESSORIES
Sfumatura bianca	Shaded white
Cristal Clear by Jacuzzi® su ambo i lati	Cristal Clear by Jacuzzi® on both sides
Appendiaccappatoio	Bathrobe hook
Porta oggetti in cristallo	Glass toiletry shelf
Supporto a parete regolabile (+/- 15mm)	Adjustable wall support (+/- 15mm)

VERSIONI DISPONIBILI	VERSIONS OFFER
Versione unica	Single version

FINITURE	FINISHES
Cromo	Chrome

CARATTERISTICHE	SPECIFICATIONS
Altezza cm	195 cm Height
Larghezza cm	86.7 cm Width
Profondità cm	37.2 cm Depth

<b>DOTAZIONI</b>		<b>ACCESSORIES</b>	
Sfumatura bianca		Shaded white	
Cristal Clear by Jacuzzi® su ambo i lati		Cristal Clear by Jacuzzi® on both sides	
Supporto a parete regolabile (+/- 15mm)		Adjustable wall support (+/- 15mm)	
<b>VERSIONI DISPONIBILI</b>		<b>VERSIONS OFFER</b>	
Sx		Sx	
Dx		Dx	
<b>FINITURE</b>		<b>FINISHES</b>	
Cromo		Chrome	
<b>CARATTERISTICHE</b>		<b>SPECIFICATIONS</b>	
Altezza	cm	140/146	cm Height
Larghezza	cm	118,5	cm Width

- 1 Cristallo ruotabile a muro.  
*Swivel wall-hung glass panel.*
- 2 Anta in cristallo.  
*Glass door.*
- 3 Cerniere.  
*Hinges.*
- 4 Guarnizione vasca.  
*Bathtub seal.*
- 5 Sfumatura bianca serigrafata.  
*Silk-screen printed shaded white.*
- 6 Supporto a parete regolabile (+/- 15mm).  
*Adjustable wall support (+/- 15mm).*

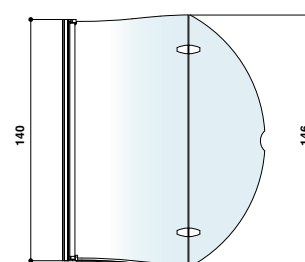
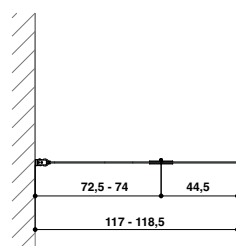
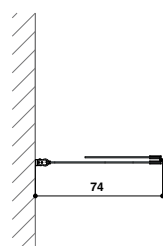
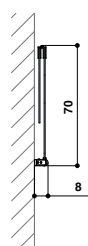
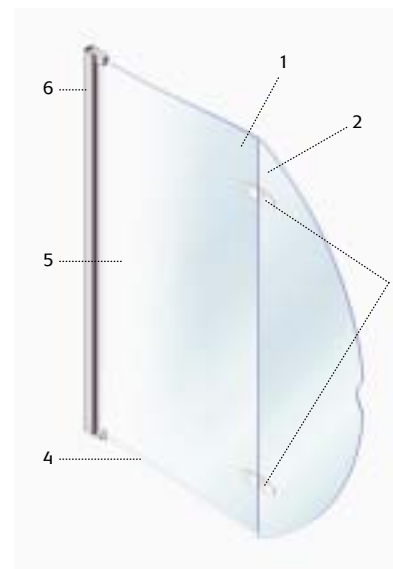



**CONCEPT**  
Ufficio Marketing Jacuzzi Europe

**GRAPHIC PROJECT**  
Vincenzo Tami

**3D IMAGING**  
Neiko srl

**TEXT**  
Daniele Varelli

**PHOTO**  
Gianni Antoniali - IKON  
**ART-STYLIST**  
Claudia Sani- IKON

**PHOTOLYPHE**  
Fotolito Udinese

**PRINT**  
Grafiche Antiga - TV

I dati e le caratteristiche indicate non impegnano la Jacuzzi Europe Spa, che si riserva il diritto di apportare delle modifiche ritenute opportune senza obbligo di preavviso o di sostituzione.

*The data and information given here are not binding for Jacuzzi Europe Spa, which reserves the right to make any modifications necessary without prior notice or replacements.*